



OFFSHORE TERMINAL HANDBOOK

MAN - Manual

Document No.: X060-A1-MAN-60002
Security Classification: Public

Issued For Use

Rev	Date	Description	Prepared	Checked	Line Manager endorsed	Director / GM approved
1	13/09/2018	Issued for Use	Paul Hardman	Bruce Macgregor	Neville Carrington	
2	15/11/2018	Issued for Use	Peter Bartlett	Bruce Macgregor	Bruce Macgregor	Neville Carrington
3	04/02/2019	Issued for Use	Peter Bartlett	Bruce Macgregor	Bruce Macgregor	Neville Carrington

Table of Contents

1	ICHTHYS FIELD GENERAL INFORMATION	1
1.1	Ichthys Field	1
1.2	Offshore Facilities	2
1.3	Onshore Facilities.....	4
1.4	Ichthys Field Climate and Local Environment.....	5
1.5	Weather forecasting & Monitoring	6
1.6	Time Zone	7
1.7	Legislation	7
1.8	Safety and Security Zones	8
1.9	Cautionary Area, Anchoring & Hazards to Navigation.....	13
1.10	Navigation and Pilotage requirements.....	15
1.11	Terminal Organisation, Roles and Responsibilities	16
1.12	Quarantine, Ballast Water and Pollution	18
1.13	Fauna Interaction.....	18
1.14	SIMOPS	18
2	REPORTING & COMMUNICATIONS	20
2.1	Pre-Arrival Reporting.....	20
2.2	Notice of Readiness.....	20
2.3	Internal Terminal Communication Plan	20
2.4	External Terminal Communication Plan	21
2.5	TORZ, Security and Petroleum Safety Zone Control Procedure.....	21
2.6	Emergency Contact	21
3	TERMINAL INFORMATION.....	22
3.1	FPSO Layout.....	22
3.2	Parameters for facility operations.....	22
3.3	Field Condensate specifications.....	24
3.4	Equipment	24
3.5	Terminal Services	25
4	SAFETY INFORMATION	28
4.1	Incident reporting	28
4.2	Fire Prevention	28
4.3	Spills.....	30
4.4	High Risk Activities.....	30
4.5	Security.....	31
5	TERMINAL CONDITIONS & DECLARATIONS	33
5.1	Terminal Conditions	33
5.2	Declarations	33
5.3	Pre and Post Offtake Briefings	33
6	MOORING OPERATIONS.....	34

6.1	Pilot Master Exchange.....	34
6.2	Terminal Pilotage Passage Plan	34
6.3	Offtake Hose	34
6.4	Static Tow Operation	34
7	LOADING OPERATIONS.....	36
7.1	Cargo Loading Plan	36
7.2	Inspections prior to loading	36
7.3	Testing the ESD Systems	36
7.4	Inert gas systems	36
7.5	Suspension and resumption of cargo operations	36
7.6	Completion of loading	36
7.7	Manifold draining	36
7.8	Cargo sampling and Lifter Final Retention Sample	37
8	DEPARTURE OPERATIONS.....	38
8.1	Offtake Hose disconnection and Unmooring Procedure.....	38
8.2	Shipping Documentation	38
8.3	Offtake Tanker Environmental Report	38
8.4	Offtake Time Sheet	38
8.5	Early Departure Procedure	38
9	EMERGENCY RESPONSE	39
9.1	Emergency Response Procedures	39

List of Tables

Table 1 - BDC Coordinates.....	9
Table 2 - Ichthys Production Facilities PSZ Boundaries	10
Table 3 - Offloading Weather Limits	23

List of Figures

Figure 1 - Ichthys Field	1
Figure 2 - Ichthys Offshore Facilities	2
Figure 3 - Subsea Structures.....	3
Figure 4 - CPF	4
Figure 5 - Ichthys Onshore Facilities	5
Figure 6 - Application of Offshore Legislation.....	8
Figure 7 - Brewster Drill Centre Petroleum Safety Zones	9
Figure 8 - Offshore Facility Petroleum Safety Zones	11
Figure 9 - Offtake Tanker No Go Zone	13
Figure 10 - Charted Locations of Ichthys & Prelude Facilities, PSZ's & Cautionary Area ..	14
Figure 11 - Met-Ocean Buoy Location	15
Figure 12 - FPSO Configuration	22

List of Appendices

APPENDIX A:	ICHTHYS FIELD CONDENSATE SHIP-SHORE QUESTIONNAIRES - TERMINAL COMPATIBILITY	40
APPENDIX B:	PILOT BOARDING ARRANGEMENTS.....	45
APPENDIX C:	ENCLOSURES.....	46
C.1	INPEX FPSO Offloading Meeting	46
C.2	Pre-Loading Meeting Agenda	49
C.3	Post Loading Meeting Agenda	51
C.4	FPSO Terminal Conditions of Use	52
C.5	Acceptance of Terminal Conditions of Use	63
C.6	Safety Letter	64
C.7	Security Declaration	65
C.8	Approved Smoking Areas	67
C.9	Offtake Tanker Environmental Report	68
C.10	Offtake Time Sheet	69
C.11	Cargo Loading Plan	72
C.12	Offtake Tanker / Terminal Safety Checklist.....	75
C.13	Notes Of Protest	82
C.14	Weather Parameters.....	83
C.15	Terminal Feedback on Vessel.....	84
C.16	Vessel Feedback on Terminal.....	88
C.17	Inpex Master Pilot Exchange Ichthys Field.....	92
C.18	Ichthys Venturer Terminal - Pilotage Passage Plan	98
C.19	Special Instructions.....	102
APPENDIX D:	GLOSSARY.....	103

NOTICE

All information contained with this document has been classified by INPEX as Public and must only be used in accordance with that classification. Any use contrary to this document's classification may expose the recipient and subsequent user(s) to legal action. If you are unsure of restrictions on use imposed by the classification of this document you must refer to the INPEX Sensitive Information Protection Standard or seek clarification from INPEX.

Uncontrolled when printed.

1 ICHTHYS FIELD GENERAL INFORMATION

1.1 Ichthys Field

In 1998, INPEX Browse Ltd acquired the petroleum exploration Permit WA-285-P located in the Browse Basin approximately 250km off the north-west coast of Western Australia. Exploration between 2000 and 2001 identified major oil and gas reserves in the permit area with the discovery subsequently being named the 'Ichthys Field'.

The Ichthys Field consists of two reservoirs; the Brewster and the Plover Formation. These reservoirs contain approximately 12.8 trillion cubic feet of gas and 527 million barrels of condensate covering an area of approximately 800km² and sitting in water depths ranging from 235m to 275m. When complete, the Ichthys Field will consist of approximately 50 subsea wells grouped into a number of drill centres (DCs), eight drill centres for the Brewster reservoir and five for the Plover reservoir.

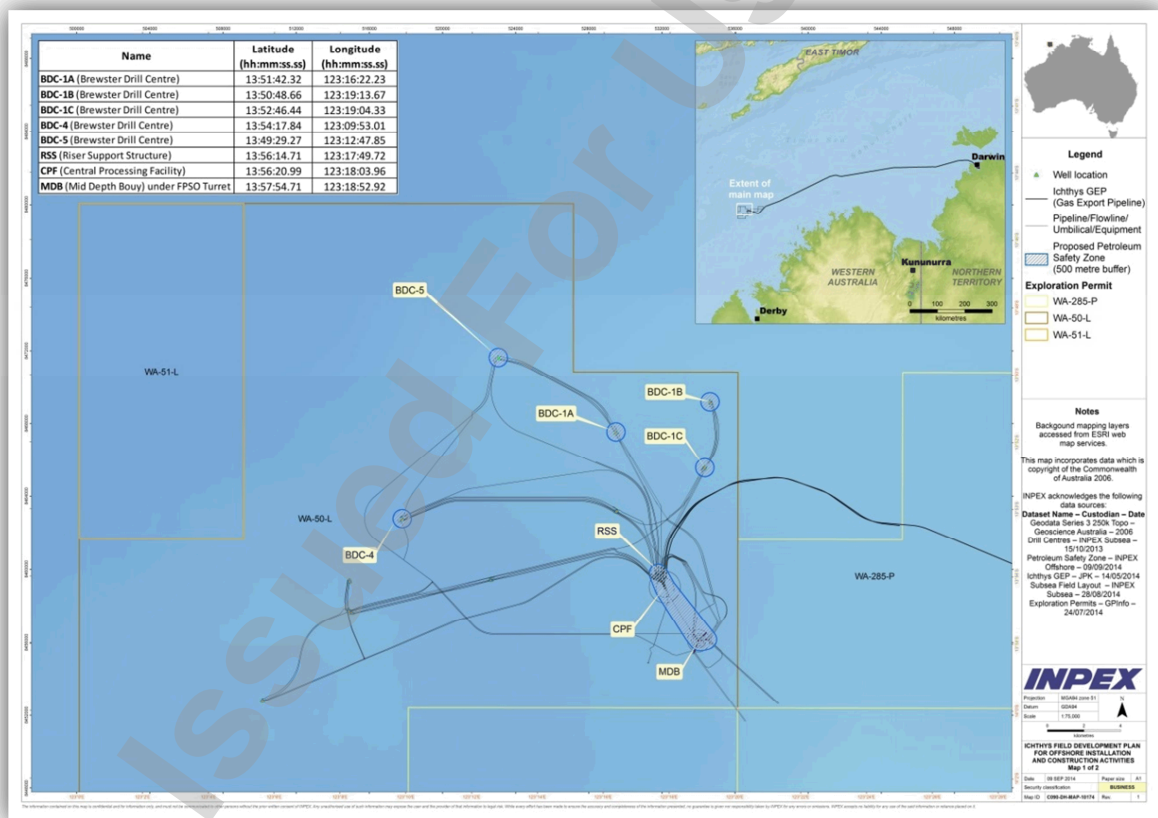

Figure 1 - Ichthys Field

The Ichthys Project uses a combination of offshore and onshore processing facilities to produce liquefied natural gas (LNG), liquefied petroleum gas (LPG) and condensate for export to customers worldwide.

Offshore facilities include subsea production systems tied-back to a floating Central Processing Facility (CPF), where initial separation of gas and liquids is carried out. Liquids are transferred to the infield Floating Production, Storage and Offloading (FPSO) which separates condensate from produced water. The condensate is stabilised and stored for direct export to market via offtake tankers. Liquid rich gas is dehydrated and compressed for export to the onshore LNG plant via the Gas Export Pipeline (GEP).

Other developments within the Browse Basin in vicinity of the Ichthys field include the Shell Prelude Floating LNG facility which will be located approximately 15 km to the north east of the Ichthys facilities.

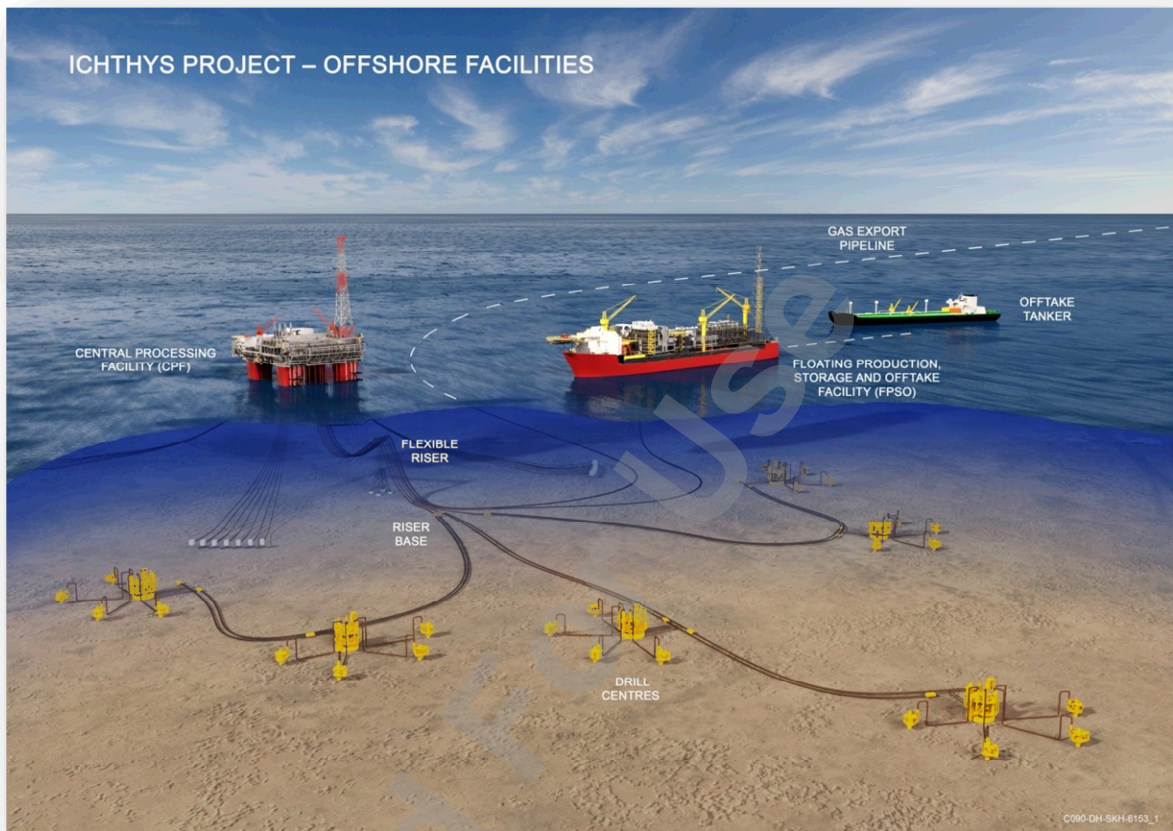

Figure 2 - Ichthys Offshore Facilities

1.2 Offshore Facilities

Floating Production Storage and Offtake

The FPSO is a non-propelled, permanently moored, mobile offshore processing and storage unit, approximately 335m long by 59m wide. The FPSO weathervanes around a geo-stationary turret which is connected to mooring chains anchored to the seabed.

The FPSOs primary functions are to:

- separate, stabilise, store and offload condensate delivered from the CPF;
- deliver MEG to the subsea wells to prevent the formation of hydrates, and recycle MEG within the condensate stream delivered from the CPF;
- compress flash gas for use as fuel gas and import / export fuel gas to / from the CPF; and
- treat produced water, for safe discharge overboard.

During normal operations, the maximum number of personnel on the FPSO is 210.

Subsea

The Ichthys subsea facilities comprise:

- wells and Christmas trees;
- manifolds and jumpers;
- production flowlines, risers and riser bases;
- infield condensate rich MEG (CRM) transfer system (between CPF and FPSO);
- infield flash / fuel gas flexible lines (between CPF and FPSO);
- umbilicals (including between CPF and FPSO);
- gas export system (to Darwin LNG Plant);
- MEG distribution system; and support structures.

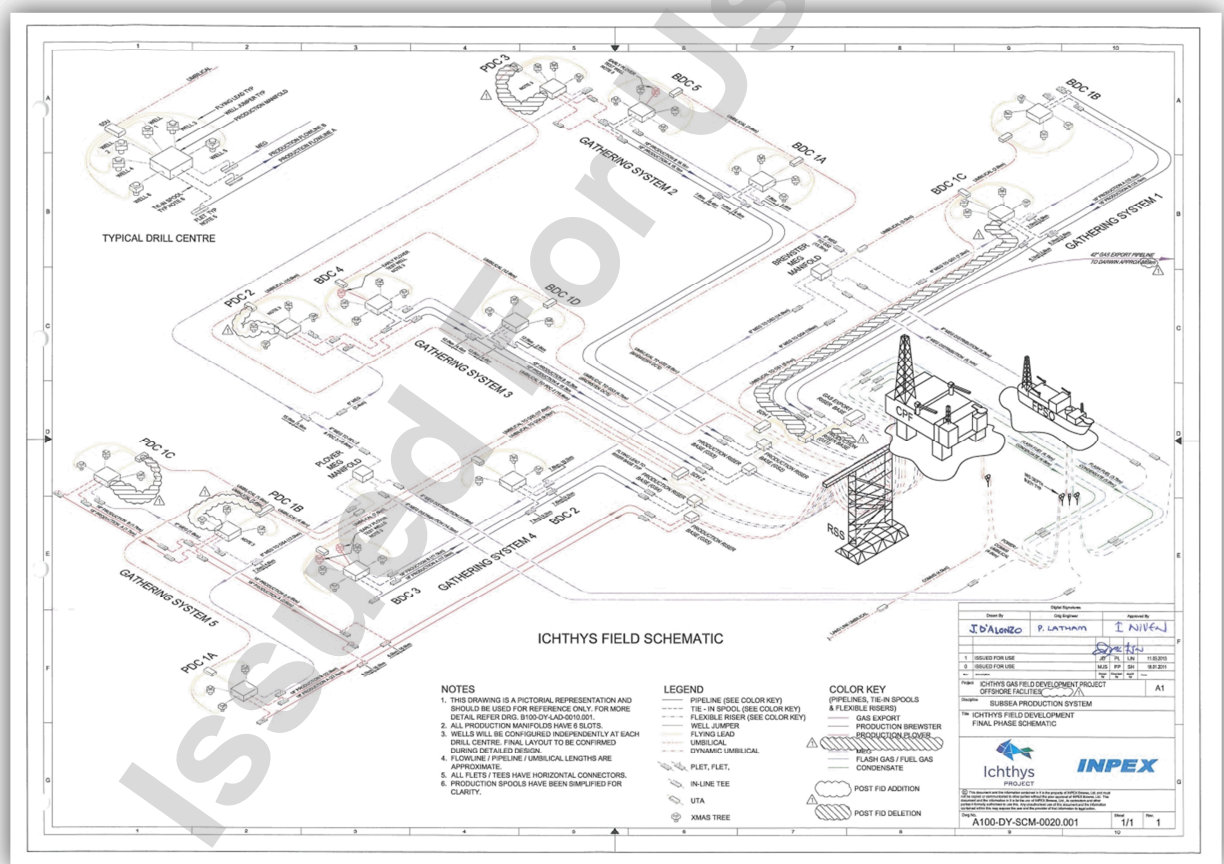

Figure 3 - Subsea Structures

Central Processing Facility

The CPF is a permanently moored, semi-submersible production unit supporting topside hydrocarbon processing systems, utilities and accommodation facilities. The CPF topside is approximately 110m x 150m. The primary function of the CPF is to process the well fluids received from the subsea wells.

Production flowlines from the various gathering systems terminate at Production Riser Bases (PRBs), and are routed to the CPF via flexible risers supported on a Riser Support Structure (RSS) and terminating at the riser balcony at the north end of the facility.

The well fluids received by the CPF are separated; the gas is dehydrated, compressed and exported via four flexible risers to the Gas Export Riser Base (GERB) and into the Gas Export Pipeline (GEP) for transmission to shore. Separated liquids are exported via flexible risers and two infield flowlines to the FPSO for further processing.

Flash gas generated and not used by the CPF for fuel gas is routed to the FPSO via flexible risers and two infield flash gas / fuel gas flowlines.



Figure 4 - CPF

1.3 Onshore Facilities

The onshore plant is located at Bladin Point near Darwin in the Northern Territory. Gas and residual condensate are separated at the onshore plant inlet facilities. The condensate is stabilised and stored for export while the gas is processed and liquefied in two LNG trains each producing 4.2 mtpa of LNG for storage and export. Liquefied propane and butane are also produced in the LNG trains for export as separate products.



Figure 5 - Ichthys Onshore Facilities

1.4 Ichthys Field Climate and Local Environment

The meteorological conditions in the area can be summarised as follows:

- The winter season (April to September) is characterised by steady northeast to southeast winds of 10 to 24 kts, which bring predominantly fine conditions throughout the north of Australia.
- The summer season (October to March) is characterised by northwest to southwest winds of 10 kts for periods of 5 to 10 days with surge in airflow of 16 to 24 kts for periods of 1 to 3 days. During summer season, weather is largely determined by the position of the monsoon trough, which can be in either an active or an inactive phase.
- The active phase is usually associated with broad areas of cloud and rain, with sustained moderate to fresh north-westerly winds on the north side of trough. Widespread heavy rainfall can result if the trough is close to or over land.
- The inactive phase occurs when the monsoon trough is temporarily weakened or retreats north of Australia; it is characterised by light winds, isolated shower and thunderstorm activity, sometimes with gusty squall lines.
- The region is subject to severe tropical cyclone activity. Tropical cyclones can develop off the coast in summer season, usually forming within an active monsoon trough. During cyclones in the region, mean wind speeds can be as high as 126 kts with gust up to 210 kts, with a maximum wave height of 32m.

- Waves generated by local winds have a similar pattern to the ambient wind conditions. However, the total waves (includes sea and swell) are mainly from west-south-west to southwest.
- It is unlikely that a tsunami wave height would exceed 2m given the water depth.
- The surface current direction has a relatively even distribution at the Ichthys field, with speeds typically less than 1 kt, reaching up to 1.6 kts.
- Seawater temperatures vary between 21°C and 31°C on the surface and 10°C and 16°C at seabed level.
- Annual visibility at the Ichthys location is in the order of >5nm 95% of the time and <2nm 5% of the time.
- The seabed over the site is characterised as featureless soft sandy silt to varying grades of sand in the form of sand waves.
- The shallow soils identified within the infield development area have been interpreted to comprise silt / sand and clay, providing a stable environment for construction.
- Three sand wave zones are identified in the infield area.
- No subsea hazards have been identified within the infield development, other than the existing exploration well locations.

1.5 Weather forecasting & Monitoring

Field weather forecasting is available to visiting tankers on request through their agent.

A meteorological system is installed on CPF platform to provide real time and historical weather data of the Ichthys field's conditions including a Met-Ocean buoy in the vicinity of the platform. The Buoy location is provided in Hazards to Navigation section of this document.

Environmental Monitoring System (EMS) software is used to control and manage all sensor inputs and data outputs. The EMS server is accessed on site or remotely with a secure logon.

The EMS will monitor and report of the following weather data:

- wind speed and direction
- temperature and humidity
- barometric pressure
- rainfall
- cloud height
- visibility
- heading (from gyrocompass)
- wave height, wave period, wave direction, current speed, current direction and sea temperature (from wave buoy)
- precipitation detection (weather radar)

This information is able to be provided to the Australian Bureau of Meteorology (BoM) via FTP for improved local weather forecasting purposes.

1.6 Time Zone

Ichthys Offshore facilities operate on UTC +08 hrs.

1.7 Legislation

The FPSO is located in Australian Commonwealth Waters and the applicable legislation and regulations include:

- Offshore Petroleum and Greenhouse Gas Storage Act (OPGGSA) 2006; and
- Offshore Petroleum and Greenhouse Gas Storage (Safety & Environment) (OPGG(S)&(E)) Regulations 2000
- Environment Protection and Biodiversity Conservation Act 1999 & Regulations 2000
- Maritime Transport and Offshore Facilities Security Act & Regulations 2003
- Protection of the Sea (Prevention of Pollution from Ships) Act 1983
- Protection of the Sea (Harmful Anti-fouling Systems) Act 2006
- Environmental Protection (Sea Dumping) Act 1981

Vessels which are not considered facilities will operate under Flag State and Australian Maritime legislation and associated regulations including:

- Navigation Act 2012
- Occupational Health and Safety (Maritime Industry) Act 1993
- Biosecurity Act 2015 and Regulations 2016
- Environment Protection and Biodiversity Conservation Act 1999 and Regulations 2000
- Protection of the Sea Acts
- Environmental Protection (Sea Dumping) Act 1981
- AMSA Marine Orders

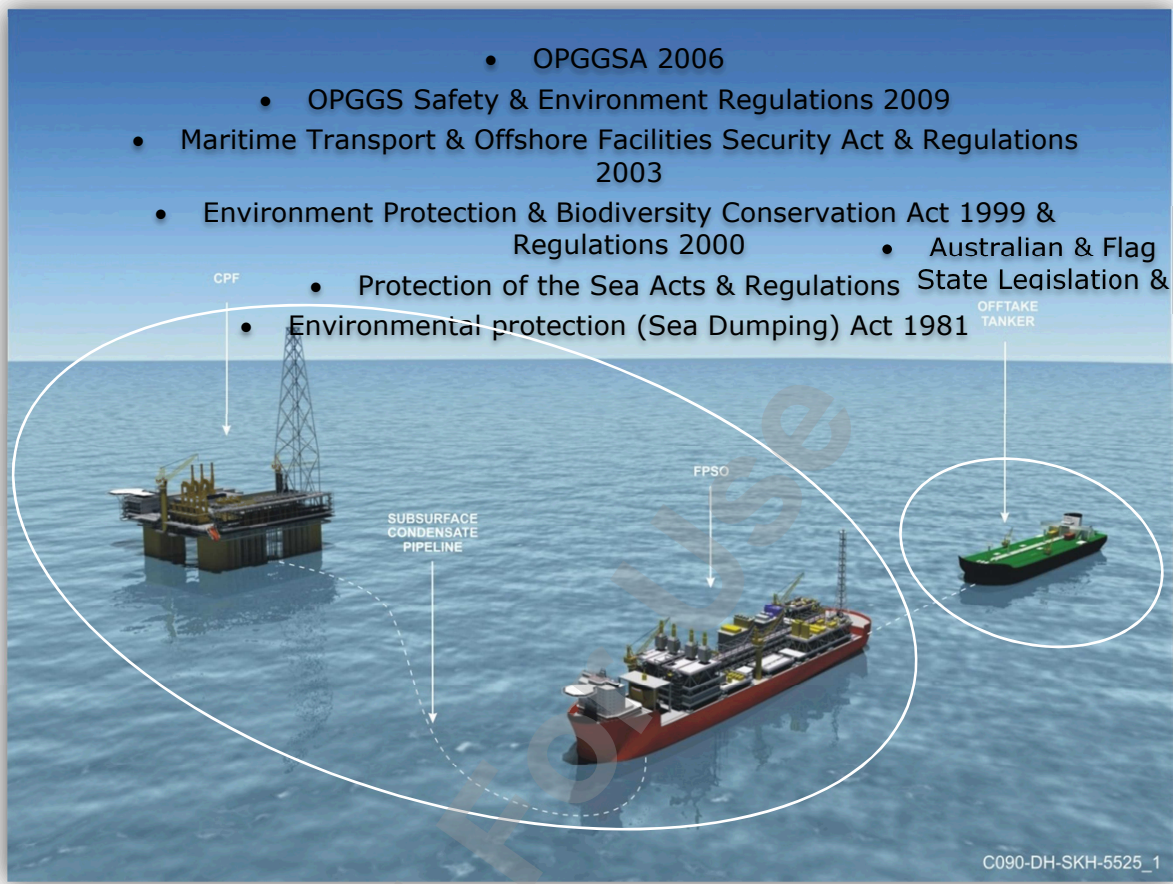

Figure 6 - Application of Offshore Legislation

1.8 Safety and Security Zones

Petroleum Safety Zone

Pursuant to section 616 of the Offshore Petroleum and Greenhouse Gas Storage Act 2006 NOPSEMA has declared Petroleum Safety Zones (PSZ) around Ichthys facilities, subsea structures and equipment.

These zones prohibit all vessels other than vessels under the control of INPEX Operations Australia Pty Ltd the registered holders of WA-50-L and vessels operated by authorised persons who are exercising powers under section 615(1) of Division 1 of Part 6.6 of the above Act from entering or being present in the area of the petroleum safety zones without the consent in writing of NOPSEMA.

The petroleum safety zones extend to a distance of 500 metres, measured from each point of the outer edge of the Drill Centres as described in Table 1 - BDC Coordinates and Figure 7 - Brewster Drill Centre Petroleum Safety Zones.

A petroleum safety zone also extends to a distance of 500 metres, measured from each point of the outer edge of the facilities contained within the area identified by coordinates in Table 2 - Ichthys Production Facilities PSZ Boundaries and shown in Figure 8 - Offshore Facility Petroleum Safety Zones which include:

- Ichthys permanently moored Semi-Submersible Central Processing Facility (CPF) and FPSO.

- Subsea infrastructure supporting and connecting flexibles to the permanently moored Floating Storage and Offtake Facility (FPSO) turret (from CPF)
- Flexible Risers connecting Flowlines to CPF topsides, supported at mid-length by 130m tall Riser Support Structure (RSS)
- Flow line end terminations connecting seabed flexible section of condensate transfer line which rises to the FPSO turret via MDB to rigid lines
- Hydrocarbon Transfer lines between CPF and FPSO.

Table 1 - BDC Coordinates

Petroleum Safety Zone Centres (GDA94)		
Drill Centre	LATITUDE S	LONGITUDE E
BDC-1A	13° 51' 42.32"	123° 16' 22.23"
BDC-1B	13° 50' 48.66"	123° 19' 13.67"
BDC-1C	13° 52' 46.44"	123° 19' 04.33"
BDC-4	13° 54' 17.84"	123° 09' 53.01"
BDC-5	13° 49' 29.27"	123° 12' 47.85"

**Figure 7 - Brewster Drill Centre Petroleum Safety Zones**

Table 2 - Ichthys Production Facilities PSZ Boundaries

Petroleum Safety Zone Boundary (GDA94)		
No.	LATITUDE S	LONGITUDE E
PSZ1	13° 58' 07.75"	123° 19' 16.73"
PSZ2	13° 57' 41.25"	123° 19' 21.76"
PSZ3	13° 56' 56.01"	123° 18' 41.47"
PSZ4	13° 56' 11.66"	123° 18' 08.46"
PSZ5	13° 55' 48.22"	123° 17' 54.85"
PSZ6	13° 55' 40.58"	123° 17' 32.34"
PSZ7	13° 56' 01.85"	123° 17' 24.58"
PSZ8	13° 56' 27.29"	123° 17' 35.15"
PSZ9	13° 57' 12.23"	123° 18' 03.91"
PSZ10	13° 58' 06.82"	123° 18' 42.08"

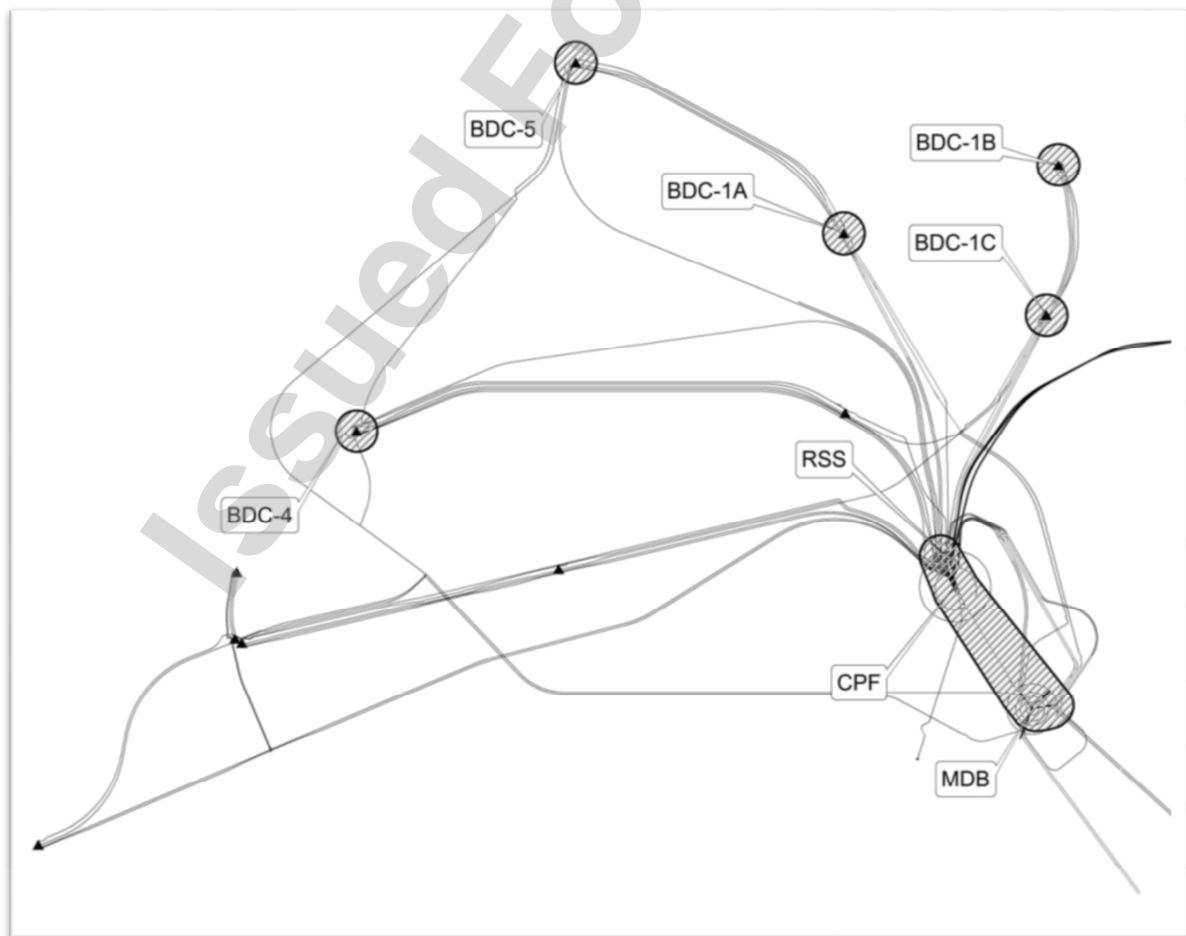
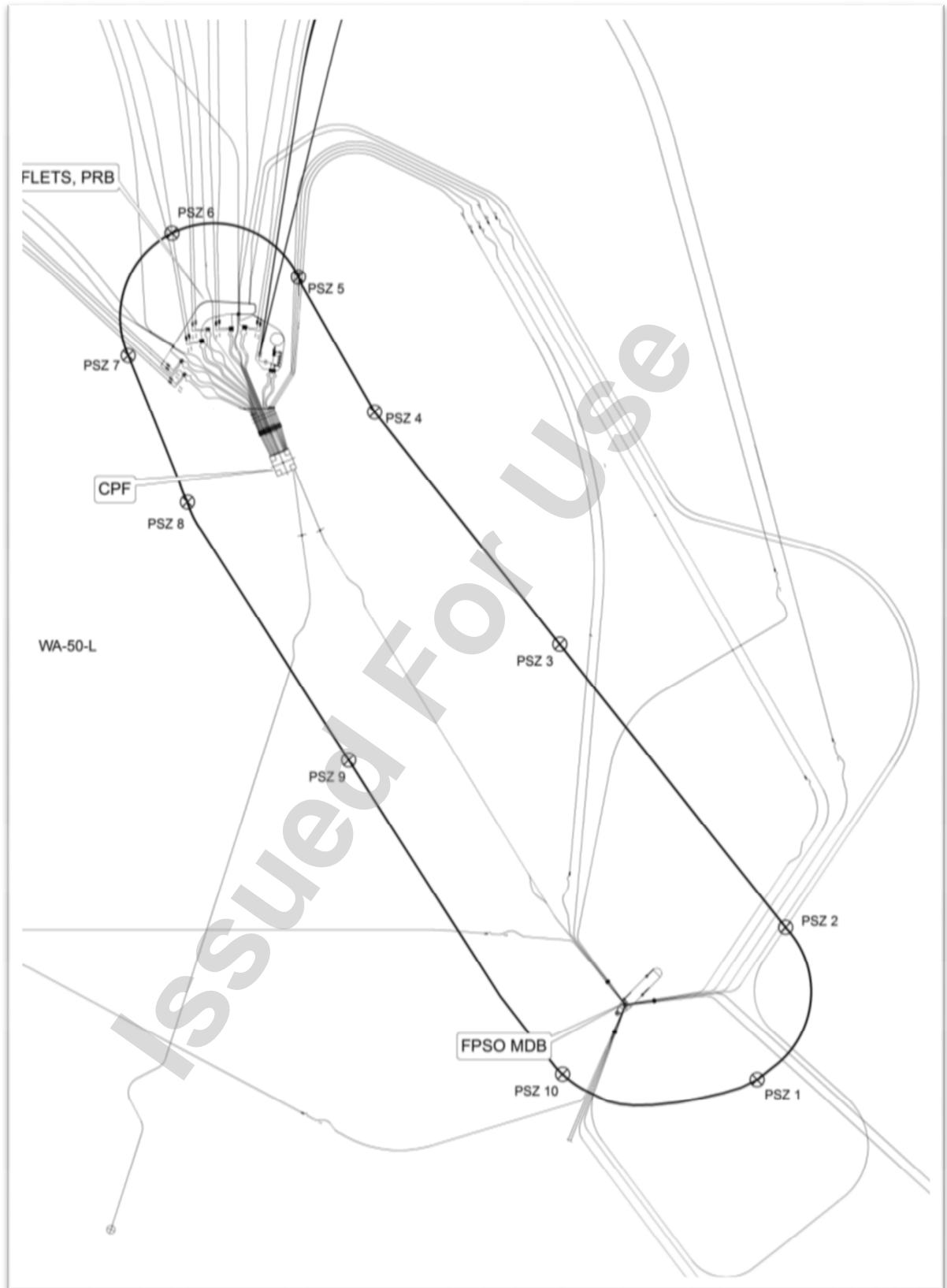

Figure 8 - Offshore Facility Petroleum Safety Zones

Offshore Security Zones

The FPSO and CPF will be Security Regulated Offshore Facilities controlled as required under the Maritime Transport and Offshore Facilities Security Act 2003 and associated Regulations.

An Offshore Security Zone (OSZ) will apply to each facility with requirements outlined in the Offshore Facility Security Plans of each facility. Plans will set out security measures and procedures to monitor and control access to the zone, including measures to detect and deter unauthorised access to the zone.

Ship Security Zone

From time to time there may be SSZ's in force around field construction vessels, including Mobile Offshore Drilling Units (MODUs), Accommodation Support (ASV), Inspection Maintenance Repair vessels (IMR) and other vessels, which must be adhered to at all times. Visiting vessels are to take care when approaching the field to ensure they remain clear of these security regulated vessels.

Tanker Operations Restricted Zone

A company declared 5nm Tanker Operations Restricted Zone (TORZ) has been established around the FPSO and CPF and applies exclusively to Tankers visiting the Ichthys Terminal.

The purpose of this zone is to control tanker access to:

1. The water space around the CPF and FPSO before an offtake is to occur at the Terminal
2. Provide a healthy buffer for potential simultaneous operations and
3. Restrict onboard activities such as anchoring, welding and burning, dumping of waste while in vicinity of the Terminal.

Further details on limitations within the TORZ are described in relevant sections.

Offtake Tanker No Go Zones

Offtake Tankers are advised that a No Go zone is in force around the CPF. The sector is centred on the FPSO and extends from 290 Deg T clockwise to 005 Deg T to a maximum range of 5nm from the CPF. This zone must be avoided during approach to and departure from the Terminal. Whilst moored at the Terminal, the offtake tanker with the assistance of the Offshore Support vessel (OSV) will make best endeavours not to enter the No Go Zone. In the event the No GO Zone is entered, the OSV will be used to swing the offtake tanker through this zone. The No Go Zone is depicted in Figure 9 - Offtake Tanker No Go Zone.

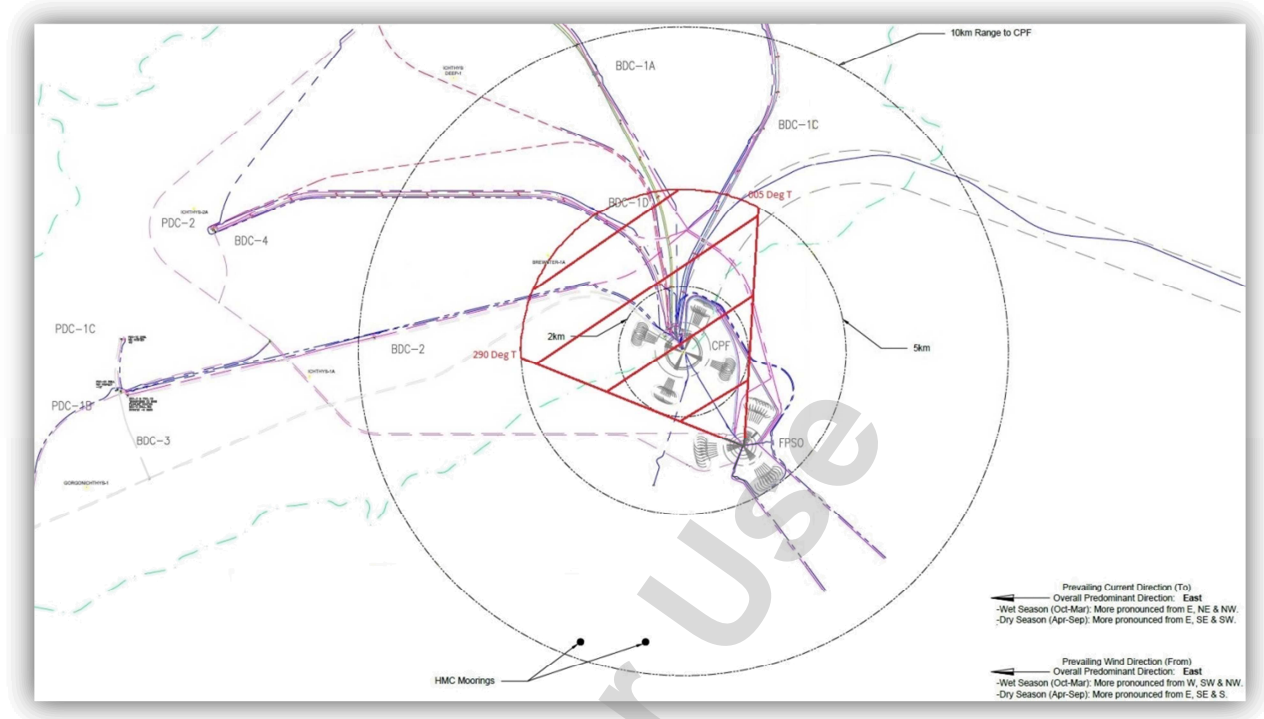

Figure 9 - Offtake Tanker No Go Zone

1.9 Cautionary Area, Anchoring & Hazards to Navigation

Cautionary Area

The FPSO Ichthys Venturer is located in position

Lat: 13° 57.15' S

Long: 123° 18.15'E

Subsea equipment extends more than 8.5 nautical miles from the CPF and is protected by PSZ's. Under no circumstances shall any vessel enter a PSZ's without Company approval.

Australian Notice to Mariners Marine Notice 242/16 promulgated an Infrastructure cautionary area north-westwards of Browse Island. The Cautionary Area encompasses Ichthys and Prelude Offshore facilities.

Figure 10- Charted Locations of Ichthys & Prelude Facilities, PSZ's & Cautionary Area depicts this information.

Anchoring

Due to water depth and proximity of subsea structures anchorage in the field is prohibited. Visiting Tankers are to have their anchors secured by at least two deployment preventers whilst within the TORZ. Anchor cables are to be secured by the guillotine & locking pin and also by wire and turnbuckle arrangements. The Ichthys Pilot will visually check this, prior to requesting approval to berth.

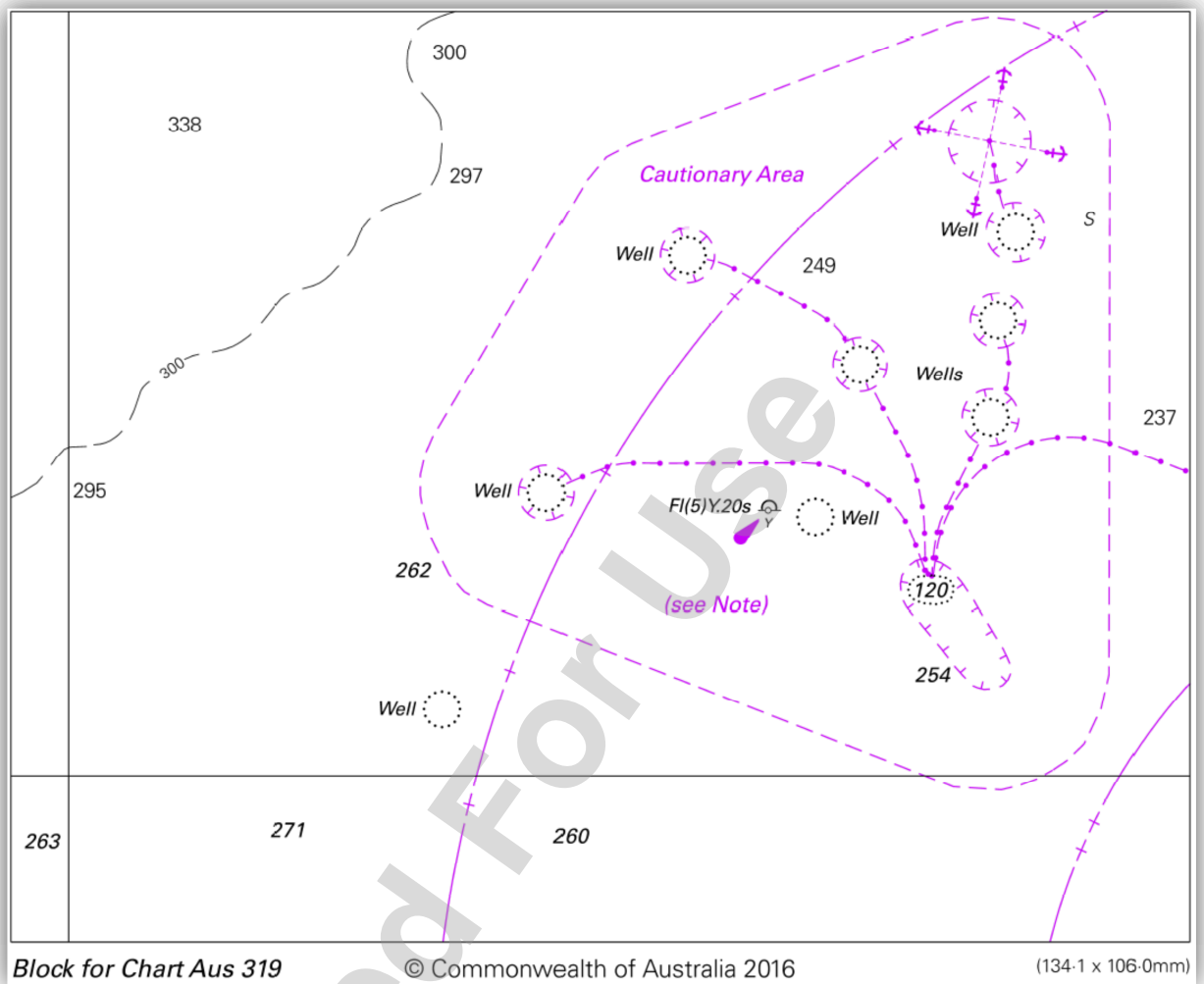

Figure 10 - Charted Locations of Ichthys & Prelude Facilities, PSZ's & Cautionary Area

Hazards to Navigation

A Met-Ocean Buoy and subsurface mooring and monitoring system is positioned in the following coordinates:

Lat: 13° 56' 12.56" S

Long: 123° 15' 51.65" E

Figure 6 depicts the relative location of the buoy to the CPF.

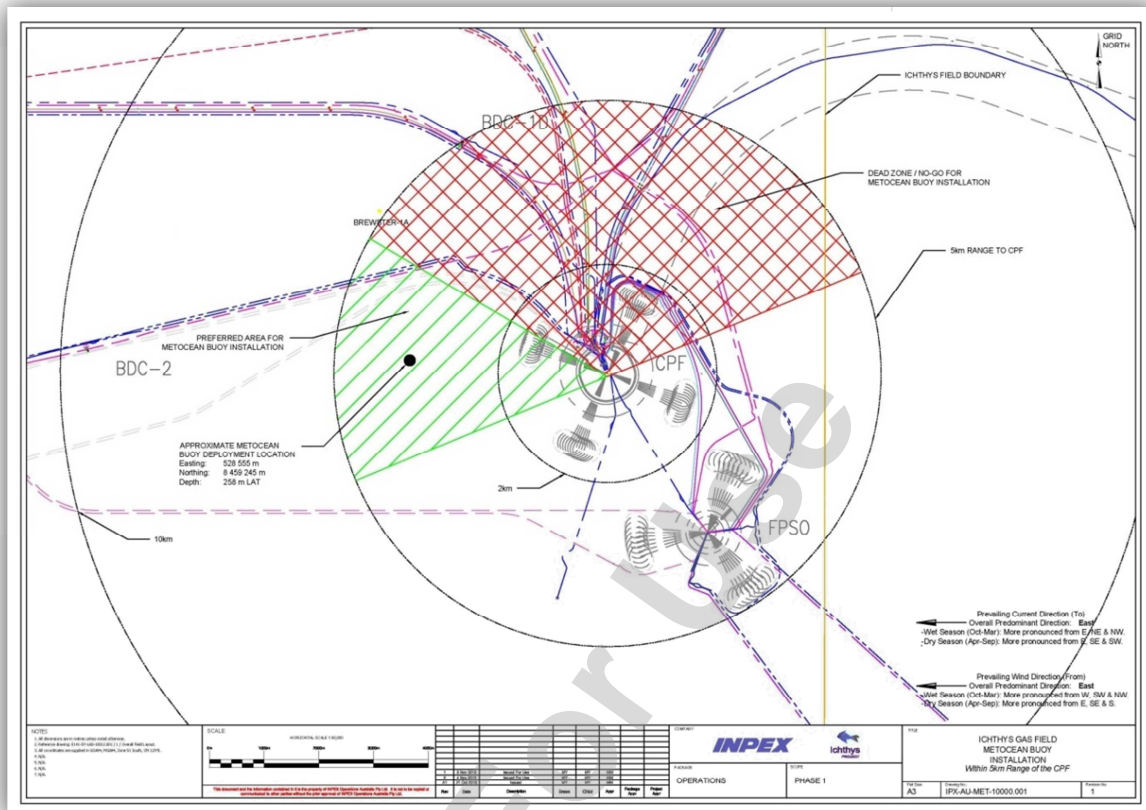

Figure 11 - Met-Ocean Buoy Location

1.10 Navigation and Pilotage requirements

Pilotage of the Offtake Tanker by a company approved / appointed Pilot, is compulsory within 3nm of the FPSO.

An Offtake Tanker holding outside the TORZ will be directed by the Terminal to a specified boarding ground at least 3 nm from the stern of the FPSO based on the prevailing weather conditions and instructed to make a lee for the OSV.

The Pilot and Assistant Mooring Master / Terminal Surveyor will then board the Offtake Tanker and commence the pilotage and mooring process. Once moored these personnel shall remain onboard for the duration the Offtake Tanker is moored at the Facility and suitable accommodation shall be provided.

On completion of the offtake operation the Pilot with the Assistant Mooring Master will take charge of the disconnection and manoeuvre the Offtake Tanker to a safe distance clear of the FPSO where they will disembark to the OSV.

Only Daylight hour berthing's at the Terminal is supported however day and night departures are permitted.

1.11 Terminal Organisation, Roles and Responsibilities

Field Manager / CPF OIM

A Field Manager will be permanently based in the field and will have responsibility over all Health Safety and Environmental aspects within the Ichthys Field including SIMOPS and Emergency Response. They are accountable for:

- ensuring compliance with INPEX and regulatory health, safety and environmental requirements for all activities conducted within the field.
- identifying, coordinating and managing clashes or conflicts between activities which are deemed to constitute SIMOPS.
- defining global work priorities conducted within the field to avoid SIMOPS (which may lead to deviation from an approved detailed work time schedule).
- assuming the role of Field Incident Commander managing emergency response operations in an event of an Incident in the field.
- ensuring a delegate is in place for periods whenever unavailable.

FPSO OIM

Offshore Installation Manager – INPEX Operations person at the Terminal who is in command and responsible for its safe operation when on duty and is responsible for implementing and supervising procedures in the event of an emergency at the facility.

Offshore Operations Marine Advisor

The Offshore Operations Marine Advisor based in Perth is responsible for:

- ensuring that effective procedures are developed, maintained and promulgated for all marine operations
- contract management of INPEX chartered vessels and management of day to day marine activities to ensure safe, reliable and efficient operations
- managing the provision of pilotage, quantity surveying and marine offtake support to FPSO operations
- liaising with Pilot / Loadmaster as required regarding all aspects of the Offtake operations
- providing technical marine advice
- liaising with the Offtake Co-ordinator for Condensate lifting's
- ensuring that all marine activities occurring within the Terminal are carried out in a safe manner in compliance with all relevant legislation, conventions, codes, procedures and standards
- participate in Operations Emergency and Pollution Response processes as required

Tanker Master

Tanker Master - person in command of the Offtake Tanker having overall control and responsibility for their vessel. The Tanker Master shall ensure that all activities on board the Offtake Tanker are carried out in compliance with the requirements of this handbook and all applicable legislation, conventions, codes, procedures and standards.

Pilot / Loadmaster

A Master Mariner provided by INPEX to perform the dual roles of Pilot and Loadmaster in order to:

- review the relevant Terminal Operating Procedures with the Offtake Tanker Master before proceeding to the Berth, and confirm any special conditions imposed either by the tanker or the prevailing local conditions.
- ensure that all the required documentation, checks, inspections and checklists are completed
- undertake the pilotage of the Offtake Tanker in a safe manner in keeping with good practice of seamanship.
- in combination with the Assistant Mooring Master direct the offtake tanker's officers and crew in berthing and hose connection operations
- be responsible for verification of all required safety checks and inspections prior to the commencement of cargo operations
- ensure that the cargo operations on board the Offtake Tanker are conducted in a manner consistent with good tanker practice, the Terminal operational procedures, ISGOTT and MARPOL requirements. Should any deficiencies or unsafe activities be noted, the Loading Master shall take any required action to rectify the deficiency and/or stop cargo operations immediately. In this case the Terminal's OIM shall be notified.
- shall ensure that the connection of the export hose to the Offtake Tanker's manifold and OSV operations are carried out in a safe manner.

Assistant Mooring Master - Terminal Surveyor

The Assistant Mooring Master is a person appointed by the Operator to provide quality & quantity surveying, mooring/unmooring and hose connection/disconnection services on the Offtake Tanker.

The Assistant Mooring Master shall be responsible for confirming the quantity of condensate from the Terminal to the Offtake Tanker and preparing all of the associated commercial documentation required on completion of the offtake.

Buyers Surveyor

In accordance with the FLA, each Lifter at its own expense may arrange for independent inspection of quantity and quality of condensate by a Buyers Surveyor during loading operations.

In the event that the Lifter exercises their right to conduct an independent inspection, the Lifter must notify the Operator no later than five (5) Working Days prior to the first day of the applicable Loading Date Range.

As a minimum the attending Buyers Surveyor must hold a current TBOSIET, MSIC and Offshore Medical and complete a facility induction. Lifters are to contact the Offshore Operations Marine Advisor in order to validate required competencies and coordinate travel arrangements.

Offtake Coordinator

The Offtake Coordinator is appointed under the FLA to calculate entitlements, administer condensate Liftings and coordinate the schedule between the Lifters in accordance with the requirements of the FLA.

OSV Master

Vessel Master – has overall responsibility for all marine operations concerning their vessel, protection of the environment and the safety of their respective vessels and for health and safety of all persons on board.

OSV Crew

Vessel Crew must comply with the vessel operator's SMS, policies, procedures, work instructions and standing orders to ensure safe, reliable and efficient operations.

1.12 Quarantine, Ballast Water and Pollution

Quarantine

Condensate tankers are to comply with the 2015 Biosecurity Act, Biosecurity Regulations and Ichthys Offshore Quarantine Management Plan.

Ballast Water

Visiting Offtake Tankers are to ensure ballast water exchange has taken place prior to field arrival in accordance with the 2015 Biosecurity Act and 2016 Regulations. Evidence of ballast water exchange shall be provided to the Pilot, prior to approval to proceed to the Terminal.

Pollution

The Protection of the Sea Acts and the 2012 Navigation Act ratify the International Convention for the Prevention of Pollution from Ships, 1973 (MARPOL) and apply to all vessels including Foreign Flagged vessels within the EEZ of Australia. Offtake Vessel shall comply fully with these provisions.

Tankers are prohibited from discharging anything overboard whilst within the TORZ.

The Assistant Mooring Master / Terminal Surveyor (Section 1.11) will physically inspect Offtake tanker overboard discharge valves, confirm they are closed and apply a seal. This seal is not to be broken, until the Offtake tanker has departed the Ichthys Field.

1.13 Fauna Interaction

Environment Protection and Biodiversity Conservation Act 1999 and Regulations Part 8 govern cetacean interaction. These laws apply to all vessels including Foreign Flagged vessels within the EEZ of Australia. Offtake Vessel shall comply fully with these provisions.

1.14 SIMOPS

Simultaneous Operations (SIMOPS) is defined as performing two or more activities in an INPEX-controlled site where any, or all, of the activities can impact on the health and safety of personnel, the environment, assets, the schedule or performance of operations at that site.

SIMOPS at the FPSO may occur during the following operations:

- IMR activities
- Cargo offloading operations; and
- Other field vessel operations (e.g. lifting activities)

SIMOPS at the FPSO is managed through the implementation of the TORZ and Operations SIMOPS Interface Plan and CONOPS Plan, as described in the HSE-MS (Part 3 of the Safety Case).

Issued For Use

2 REPORTING & COMMUNICATIONS

2.1 Pre-Arrival Reporting

Notice to the Operator

The Master of the Offtake Tanker shall give Notice to the Operator and the Offtake Coordinator of the Offtake Tankers Estimated Time of Arrival (ETA) and such other information as may reasonably be required at 72, 48, 24 and 12 hours before the advised arrival time.

Time to be used for ETA is local time (UTC + 08 hours) and the first message must also include the information in APPENDIX A: Ichthys Field Condensate Ship-Shore Questionnaires - Terminal Compatibility.

Deviation Notifications

If the ETA changes by more than 2 hours after the 24 hour notice is given, the Master of the Offtake Tanker must immediately notify the Operator and the Offtake Coordinator of the new ETA.

Failure to give each or any one of the above ETAs shall increase the allowed Laytime by the number of hours by which the actual notice is less than the required notice, but the total increase in allowed Laytime shall not exceed twenty-four (24) hours.

2.2 Notice of Readiness

The Master of the Offtake Tanker or their duly authorised agent shall tender a NOR to the Operator prior to the expiration of its Loading Date Range; provided however that a NOR may only be tendered when:

1. the Offtake Tanker has arrived within the limits of the normal waiting area of the FPSO; and
2. Master of the Offtake Tanker has agreed to the FPSO Conditions of Use and is in all respects ready to load the Agreed Lifting Quantity

2.3 Internal Terminal Communication Plan

Satellite Phone

The Field Manager will be contactable by satellite phone via the following number
+61 (0)147 152 314.

Radio Communication

INPEX has provided the use of a private means of radio communications to marine vessels and facilities, Ichthys Private Marine (IPM) channels are established as follows:

- Private channels for coordination to be used and accessed by all marine vessels engaged in regular and/or long-duration Ichthys works:
- 1x Ichthys coordination channel (IPM Ch1);
- 1x Ichthys safety / emergency channel (IPM Ch2)

Private channels to liaise with and coordinate specific scopes of work:

- 1x UHF channel (IPM Ch3);

- 1x Drilling channel (IPM Ch4);
- 1x GEP channel (IPM Ch5)
- 1x INPEX Commissioning channel (IPM Ch6);
- 2x CPF channels (IPM Ch7, IP Ch8)
- 2x FPSO channels (IPM Ch9, IPM Ch10)

Important note: use of the above channels does not require radio operator certification.

2.4 External Terminal Communication Plan

Use of International Marine (IM) channels cannot be controlled or policed by Company. However, use of such channels by any vessel / facility associated with the Ichthys Project should be coordinated and must comply with ACMA stipulations.

The international channels will be used as follows:

- Emergency channels (as mandated by Regulation):
- IM Ch16 – Calling, emergency, distress;
- IM Ch67 – Distress, safety;
- IM Ch70 – Digital Selective Calling, safety, alerting

Working channels to be used for communications with vessels not equipped / configured for use with Ichthys Private channels:

- IM Ch6 – Commercial operations and air-sea rescue – general communications;
- IM Ch8 – Commercial operations – CPF, FPSO and Commissioning;
- IM Ch72 – Commercial operations – Drilling;
- IM Ch77 – FPSO Offtake;

Important note: use of the above channels requires Marine Radio Operator VHF Certificate of Proficiency (MROVCP).

2.5 TORZ, Security and Petroleum Safety Zone Control Procedure

Visiting Offtake Tankers are to establish communications with the Terminal call sign "Ichthys Venturer" once within VHF communications range on VHF CH 16 (Distress, Safety and Calling). The Terminal will then nominate a working channel for further communications.

Permission must be obtained from the Terminal before entering the TORZ, Security and Petroleum Safety Zones.

2.6 Emergency Contact

In the event of an emergency the Offtake Tanker is to alert the Terminal Central Control Room immediately via VHF CH 16 and nominated working channels. The Terminal Emergency procedures will then be enacted under the direction of the Terminal.

3 TERMINAL INFORMATION

3.1 FPSO Layout

The FPSO is laid out into key areas: the topsides process area, the turret, and the hull including living quarters (LQ), hull tanks, forward and aft machinery spaces.

The LQ, including cabins, offices and control rooms, are located towards the bow. The helideck is forward of level 7 of the LQ, and is readily accessible from the muster points.

The FPSO turret is located at the forward section of the FPSO hull, aft of the LQ and accommodates flexible risers and umbilicals, and the mooring system.



Figure 12 - FPSO Configuration

3.2 Parameters for facility operations

The Ichthys offshore facilities are designed to be on station within the Ichthys Field for its service life of 40 years and are located in area where cyclones can form and strengthen relatively quickly. The facilities are also located a significant distance offshore where helicopter flight times are in the order of 2 hours. These features of the location mean that it may not always be possible to down man prior to a cyclonic event, and therefore the facilities are designed to withstand the 1 in 10,000 year severe weather condition.

The FPSO is designed to operate up to and including 200-year return period cyclonic conditions.

The 200 year cyclonic omni-directional environment at the time of maximum Hs are as follows:

- Sea state Hs = 12.0m with Tp = 14.3s
- Associated 10m mean wind speed = 92.6kts
- Associated current speed = 2.4kts

Offtake Weather, Sea and Visibility Limitations

- Offloading Weather limits are in accordance with Table 3 - Offloading Weather Limits.

Table 3 - Offloading Weather Limits

Status	Observed Wave Height (m)	Wind (Kts) (10min Average)	Visibility (nm)
Open (No Limitations)	<2.5	<25	> 2
Restricted ¹	>2.5 and < 3.0	>25 and <35	< 2
Closed ²	> 3.0	>35	-

Note 1: No Offtake Tanker is permitted to moor. An Offtake tanker already moored may continue offtake operations subject to pilot advice and hawser load tension.

Note 2: No Offtake Tanker is permitted to moor. An Offtake Tanker already moored will be required to disconnect and depart if safe to do so.

Adverse Weather and Thunder Storms

In making the determinations regarding adverse weather and risk of lightning strike the Operators Adverse Weather Procedure (X060-AH-PRC-60017) is to be followed.

When Thunder Storms and lightning are in the immediate vicinity of the FPSO and approaching the facility, the FPSO OIM, Pilot and the Offtake Tanker Master will consult and determine if/when offtake operations will be suspended.

Offtake tankers should consider reducing venting through the mast riser and in some cases close the mast riser valve, during thunderstorm activity.

Solitons have been observed in the vicinity of the field facilities. These phenomena give rise to abrupt changes in current direction and strength. Solitons are visible on 3cm radar which provides some warning of their approach. Caution is necessary should a soliton occur whilst the offtake tanker is connected to the FPSO.

Periods of very low wind or calm conditions may allow vented hydrocarbon gases to impact the main deck and accommodation areas. Loading operations must cease for the duration of these 'calm' events.

Extreme Weather

Offshore Cyclone Management Plan (X060-AH-PLN-60001)

3.3 Field Condensate specifications

The FPSO has three reception tanks and twelve condensate storage tanks allowing for uninterrupted production for 16 days given the capacity for 1.13 million barrels (178,960 m³) of condensate. General Condensate specifications are listed below:

- Density: 760 - 790 kg/m³ @ 15 C
- TVP: <86.3 kPa at 550C
<100kPa at 600C
- RVP: <68 kPa
- BS&W: <0.3% v/v
- Salinity: < 30 ppmw
- Mercury <30 ppbw

3.4 Equipment

Configuration and limits of mooring equipment

Offloading is performed at the FPSO stern with the vessels in tandem configuration (one behind the other). The Offtake Tanker is moored to the FPSO using the hawser mooring system consisting of:

- 150 metres 32mm diameter HMPE messenger rope;
- 150 metres 78mm diameter 12 strand polypropylene pick-up rope;
- 80 metres 152mm diameter Lankhorst GAMA 98 Brand circular braided 100% nylon hawser rope, and
- 8.9 metres 76mm diameter Grade R3 chafe chain

In accordance with the Basis of Design the FPSO mooring hawser system will accommodate tankers up to 150,000 tonnes deadweight.

The hawser is transferred to the Offtake Tanker by the OSV using a messenger line and is deployed from the hawser reel. A hawser tension monitoring system, measuring the load on the hawser quick release hook, is provided to monitor the tension between the FPSO and the Offtake Tanker whilst moored at the Terminal.

If the following criterion is reached the Offtake Tanker shall be disconnected and unmoored:

1. Three occurrences of peak mooring hawser tension greater than 100 tonnes force within one hour and or
2. One single occurrence of a peak mooring hawser tension greater than 150 tonnes force.

Rates of loading Equipment

In the early years, the FPSO is expected to conduct cargo (condensate) offloading operations every 6 to 10 days. Each offloading operation, including connection and disconnection to the Offtake Tanker, will normally be achieved within 24 hours (maximum rate of 6000 m³/hr, average rate of 5000 m³/hr). Condensate passes through the custody transfer metering system before being offloaded through the floating offloading hose.

ESD Systems

ESDVs and SDVs are provided throughout the FPSO to minimise the quantity of hydrocarbons or other hazardous substances that can be released during an event.

Cargo pumps shut down on low tanks level, low blanketing gas pressure, manually from the local stop button and from ESD depression in the CCR or offloading station at the poop deck.

One Emergency Shutdown Valve (ESDV) and one shutdown valve (SDV) are located at the offloading hose reel downstream of the metering station and one ESDV is installed upstream of the metering station.

On activation the FPSO export system valves take 16 seconds to fully close. It is therefore important that the tanker loading valves do not close faster than this. This is checked and confirmed on each occasion during the 'Pre-Loading Meeting' onboard the tanker.

3.5 Terminal Services

Terminal Fee

A nominal charge is made for services supplied to Offtake Tankers by the Facility. The fee is currently Sixty Thousand 60,000 USD (exclusive of GST). The fee charged for services supplied by the Terminal is subject to periodic review and may be adjusted without prior notification.

All services provided or performed by INPEX in connection with loading from the Facility (whether on board the Offtake Vessel or otherwise) are provided and performed strictly subject to the Terminal Conditions.

Before any services are provided or performed by INPEX, the Master of the Offtake Vessel shall be required to confirm their agreement to accept and comply with the Terminal Conditions detailed at Enclosure 11.4 by signing the letter at enclosure 11.5.

Vessel Vetting

In accordance with the FLA each Lifter must give the Operator and the Offtake Coordinator at least fifteen days' notice prior to the Loading Date Range of the name of the proposed Offtake Tanker to be used for the Lifting.

The nominated vessel will be subject to clearance by the Operator in accordance with the ICHTHYS Operations Offtake Tanker Vetting Policy S060-AW-POL-0001 and will vet the vessel in accordance with good international marine practice and confirm compatibility with the FPSO.

INPEX will complete the Clearance Process for the proposed vessel as soon as reasonably practicable and in any event within 24 hours from the date of receipt of the nomination. However this period of time may be extended by the Operator, in circumstances where additional information is required to complete the Clearance Process.

OSV & Towage Services

An Offshore Support Vessel will be available infield during offtakes to provide assistance with mooring / unmooring, hose and personnel transfer, static tow and in the event of an emergency.

Berthing Aid System

The FPSO is equipped with an offloading tanker berthing aid system which provides information to aid the Offtake Tanker, Pilot and OSV in the approach and mooring to the FPSO, including alarms when pre-set conditions are exceeded. The system provides a graphical display of the FPSO, the Offtake Tanker and the OSV presenting the following information:

- FPSO and Offtake Tanker / OSV absolute and relative positions
- distance and bearings between facilities
- Offtake Tanker / speed, course and rate of turn
- FPSO and Offtake Tanker / OSV heading
- FPSO meteorological data
- FPSO hawser tension
- Automatic Identification System (AIS) information
- Emergency shutdown request alarm (from the tanker to the ICSS alarm display located in the FPSO CCR)

Navigation Aids

The FPSO is equipped with a marine navigational radar system which scans in all directions to a range of 24nm. Two Navigation Radar Scanners, a Weather Radar (fed from the CPF) and an IR Camera system on the FPSO are displayed in the CCR along with information provided from the CPF. In addition the facilities are fitted with AIS ATON which can propagate electronic information on receiving ECDIS systems.

The CCR ECDIS system is set up so that an alarm sounds on indication of a potential collision or infringement of zones.

Two RACONs (radar beacons), S-Band and X-Band are provided in accordance with International Association of Marine Aids to Navigation and Lighthouse Authorities (IALA) and IMO specifications. The RACONs are installed in a high position on the radio tower to maximise marine coverage. Morse Identifiers for the two facilities are:

Ichthys CPF – "DELTA"

Ichthys FPSO – "GOLF"

Anti-collision lighting is provided on board the FPSO to ensure that the horizontal extremities of the FPSO and designated vessel access ways are visible to any incoming vessels. The maritime light signals comply with IALA requirements. Aeronautical obstruction lighting includes:

- upper aeronautical obstruction light; and
- omni-directional obstruction lights on crane booms, radar mast and flare tower and other structures exceeding the height of the helideck by more than 15m.

Boarding Ground

The specified boarding ground will be at the direction of the Terminal based on prevailing weather conditions and will be at least 3 nm from the stern of the FPSO.

Boarding Arrangements

See section 4.4 - Boarding arrangements and Personnel Transfers

Pilots

A Company Pilot/Loadmaster will be provided for Offtakes. Further information can be found in section 1.9 Pilot / Loadmaster

Terminal Surveyor

A Terminal Surveyor appointed by INPEX will be provided for Offtakes. Further information can be found in section 1.11 Assistant Mooring Master - Terminal Surveyor

Tanker accommodation for additional personnel

For the duration of the Offtake Tanker's visit to the Terminal, suitable messing and single berth accommodation will be required for the Pilot, Terminal Surveyor and additional personnel, which may attend from time to time. Whilst the personnel from the Terminal are onboard the Offtake Tanker the Master should ensure Lifeboat capacity is sufficient for the additional Terminal personnel visiting the tanker.

Medical Services

Only emergency medical services are available to visiting vessels. The FPSO medical centre has capacity for the immediate care of multiple sick or injured persons during assessment and observation or for more serious cases prior to their medevac ashore.

In addition a telemedicine system is provided to support communications between the personnel on board the FPSO and a Company designated telehealth service provider. The system facilitates video conferencing to and from the FPSO medical centre via the INPEX network.

Storage, handling and use of medical equipment and prescription drugs is controlled and managed by the Medic located on board.

Helicopter Services & Emergency Evacuation

Only emergency helicopter services are available to visiting vessels.

General helicopter operations are scheduled for daylight hours, with night flying only conducted in an emergency. A trained helideck crew is on board the FPSO at all times to support helicopter operations and any emergency response requirements

Shore Leave/Repatriation

Not permitted.

Bunkers, Fuel, Freshwater and Stores

Not available.

4 SAFETY INFORMATION

4.1 Incident reporting

The reporting and investigation of events (incidents or high potential hazards) directly contributes to the ongoing safety of the Terminal.

All incidents and or high potential Near Miss events that occur onboard the Offtake Tanker whilst within the Terminal's PSZ are to be reported to the Operator and investigated in accordance with the INPEX Event Reporting & Investigation Procedure.

4.2 Fire Prevention

Sources of ignition, including smoking, must be carefully managed to ensure they remain separate from hydrocarbons and their vapours.

Hot Work

Hot work is strictly prohibited within the Terminal's PSZ. This prohibition covers all types of hot work and includes but is not limited to the prohibition of the use of welding equipment, cutting and grinding equipment, blow torches, soldering equipment, naked lights and non-certified/non-hazardous rated electrical and instrument appliances and test equipment.

This prohibition extends to and includes such operations in the Offtake Tanker engine room and workshops.

Nothing in this section shall prohibit the Offtake Tanker Master from undertaking an action required for the safety of the Offtake Tanker or its personnel. However, the Terminal Representative shall be immediately notified of the intention to undertake such an action requiring the use of hot work.

Smoking, Matches and Lighters

Whilst the Offtake Tanker is within the Terminal's PSZ, smoking is restricted to not more than two "public" rooms within the accommodation. These public smoking rooms will be selected with regard to security and safety by the Offtake Tanker Master in consultation with the Terminal Representative and these public smoking room doors must be kept closed except for access.

Smoking is not permitted in cabins or on the Offtake Tanker's open deck.

The carrying of matches, lighters or any source of ignition by personnel on the Offtake Tanker's open deck is strictly prohibited within the PSZ.

Use of Radar Radio and Satellite Communication equipment

Whilst the Offtake Tanker is within the Terminal's PSZ:

- The main radio transmitting aerial(s) should be earthed and not used;
- The satellite communications equipment should not be used when flammable gas and/or liquid is within four (4) metres of the antennae;
- Only permanently and correctly installed VHF equipment of a type approved for the area of installation and having an output of one (1) watt or less is allowed to be operated; and

- Only hand held VHF or UHF radio equipment, having an output of one (1) watt or less are allowed to be operated

When within the PSZ, all radars must be shut down and electrically isolated for the duration the Offtake Tanker remains within the PSZ.

Intrinsically Safe Radios

Only intrinsically safe hand held radios are to be used within the PSZ.

Helicopter operations during loading

Under normal operations, helicopters will arrive at and depart from the Terminal during daylight hours and will not preclude the cargo loading operation unless requested by either the Offtake Tanker Master or Terminal Representative in consultation with the OIM, or helicopter pilot.

Cathodic Protection - Impressed Current Systems

Condensate Tanker Impressed Current Cathodic Protection Systems are to be switched off and isolated whilst the vessel is within the PSZ.

Tank Venting

During loading operations vigilance should be exercised whilst venting tanks especially under adverse conditions where there is little or no wind. Under such conditions the Tanker Master, Loadmaster and OIM are to decide if the operation is to continue or stop until conditions improve.

Prior to the commencement of loading, all cargo tanks which are to be loaded shall have their vent system open and made common, so as to vent through the mast riser valve. Venting of tanks through the individual pressure/vacuum valves is not permitted.

Whenever tanks are isolated to prevent cross contamination the likelihood of oxygen entering the tanks should be taken into consideration and measures may need to be planned to ensure the inert condition.

Boiler "Soot" Blowing/Release

Offtake Tankers shall not blow down boilers causing "soot" release whilst within the Terminal's PSZ.

Emergency Towing-Off Pennants / Fire wires

Emergency towing wires may be rigged at the forward shoulder and stern quarter of the Offtake Tanker. If rigged they must comply with ISGOTT - Emergency Towing Off Pennants guidelines.

The wires must be in good condition with minimum diameter, compatible with the size of the Tanker. The eye of the wire must be at the same height above the waterline as at the OSV's freeboard at the bow, which is 7m from the waterline.

Vessels and Terminal Fire Fighting Equipment

All firefighting equipment must be in good working order. Portable equipment must be correctly positioned and all equipment ready for immediate use. Firefighting appliance consumables, for example foam concentrate, must be available at volumes at least meeting or exceeding minimum regulatory requirements.

Prior to the ship's arrival the Terminal must ensure that all fixed firefighting installations are in good working order, that the portable equipment is in position and all equipment is ready for use.

4.3 Spills

All visiting vessels must be constructed, equipped and operated in accordance with the Prevention of Pollution Convention (MARPOL).

Any indication of oil and/or chemical pollution or spill is to be drawn immediately to the attention of the Operator and onboard SOPEP / SMPEP plans initiated.

The Operator has limited ability to provide assistance in case of an oil and/or chemical spill from an Offtake Tanker. The Offtake Tanker Owner will be responsible for all liability and costs incurred as a result of pollution from the Offtake Tanker, in accordance with the Terminal Conditions of Use.

Any hydrocarbon spill will be managed under the Terminal's Oil Pollution Emergency Plan and Emergency Response procedures. No chemicals such as dispersants are to be applied to the hydrocarbon spill without the explicit permission of the Operator.

Overboard Discharges

With the exception of the Ballast System, Tanker overboard discharge valves are to be closed, locked and a seal placed on each discharge, prior to berthing at the Facility. These checks will form part of the Surveyor's duties. A record of the seal serial numbers will be kept by the Surveyor.

4.4 High Risk Activities

Offtake Tankers are advised that all high risk activities including Diving, Confined Space Entry, Working at heights and Permit to Work activities are not to take place within the TORZ without the approval of the FPSO OIM.

Repairs and Maintenance

Repairs and maintenance to the Offtake Tanker's machinery and equipment shall be limited to those items, which do not impair the following:

- safe and efficient operation of the Inert Gas System
- safe and efficient operation of pumproom lighting and ventilation (if applicable)
- safe and efficient handling of slops
- propulsive power or manoeuvrability
- firefighting or fire detection capability
- safe and efficient handling of cargo, ballast, bunkers and slops
- safe operation and integrity of the mooring system
- safe operation of electrical equipment in hazardous zones
- safe operation and integrity of communications equipment
- safe and efficient operation of the lifting equipment
- safe and efficient operation of main deck lighting.

Boarding arrangements and Personnel Transfers

Whenever a pilot or other person embarks or disembarks from a ship by ladder, they entrust their safety to the pilot transfer arrangements provided by the ship. Owners and Masters are required by Marine Order 21 to ensure that pilot transfer arrangements are in place and carried out in accordance with SOLAS V/23 and IMO Resolution A.1045(27) "Pilot transfer arrangements"

Pilot Boarding Arrangements and IMO Circular MSC.1/Circ.1428 illustrates the pilot ladder arrangements required by SOLAS V/23.

Within the Ichthys Field the Pilot Loading Master, Assistant Mooring Master / Surveyor and on occasions, Operator and/or Designated Authority representative(s) will board the Offtake Tanker via these ladder arrangements.

In addition it is a requirement that a suitable lee side crane and crew be available to transfer mooring and offtake hose equipment from the OSV to the Starboard midships manifold.

Main Engine(s) and Steering Gear

The Offtake Tanker's main engine(s) must remain fully operational and available for immediate use (on immediate notice or on standby) for the duration the Offtake Tanker remains within the PSZ. If there is a failure of the main engine(s), the Terminal must be informed immediately. If such failure occurs whilst the Offtake Tanker is moored to the Terminal, the Offtake Tanker shall prepare for an emergency disconnect.

Steering gear is to be kept operational and available for immediate use for the duration the Offtake Tanker remains within the PSZ.

Lifeboat Drills

Although there may be a need to conduct lifeboat drills, for reasons of Terminal safety and security, it is not permitted to put lifeboats into the water whilst within the PSZ unless in an emergency situation.

4.5 Security

Visitors to the Terminal

Due to the isolated location of the Terminal and the difficulty of arranging transport, it is not possible for non-operations personnel to visit the Terminal or the Offtake Tanker.

Alcohol and Drugs

Alcohol is not permitted in any Operator workplaces. All personnel within the PSZ must have a Blood Alcohol Concentration (BAC) of not more than 0.00%.

The use, possession, sale, distribution and/or manufacture of illegal drugs is not permitted and personnel must not sell or distribute their own prescribed or over-the-counter medication to others.

Alcohol and other Drug testing may be conducted in accordance with the Company's Alcohol and Other Drugs Procedure (PER-00202520). If personnel return a positive reading they will be deemed unfit for work and removed from the workplace.

Photography/Electronic Equipment

Use of non-hazardous area rated electronic cameras, video equipment, mobile phones or any other portable electronic device on the Offtake Tanker's open deck is strictly prohibited within the Terminal's PSZ.

Swimming and Fishing

Personnel are not allowed to swim or dive or engage in fishing of any description from the Offtake Tanker whilst within the TORZ.

MOU Box FFV's and SEIV's

A Traditional Fishing Memorandum of Understanding (MOU) between Australia and Indonesia applies to the operations of traditional fishermen in the area adjacent to Ashmore Reef, Cartier Islet, Browse Island, Seringapatam Reef and Scott Reef. For details see Seafarers Handbook for Australian Waters AHP 20.

Vessel Incursions to Waterside restricted zones

The offshore environment INPEX Australia operates in is utilised by various mariners who have the potential to intentionally or unintentionally cause disruption to operations.

The Unplanned Maritime Contact Guideline (PER-2150952299) is to be followed in the event of a developing waterside security situation.

Issued For Use

5 Terminal Conditions & Declarations

5.1 Terminal Conditions

Terminal Conditions are presented in Enclosure 11.4

5.2 Declarations

Acceptance of Terminal Conditions

Offtake Tanker Masters are to understand the Terminal Conditions presented at 11.4 and complete the Acceptance of Terminal Conditions Declaration at 11.5 prior to commencing the berthing approach to the facility.

Safety Letter

Offtake Tankers are to sign the Safety Letter at enclosure 11.6 prior to commencing the berthing approach to the Facility.

Security Declarations

Offtake Tankers are to complete the Security Declaration at enclosure 11.7 prior to commencing the berthing approach to the Facility.

Approved Smoking Areas

Offtake Tankers are to complete the Approved Smoking Area Declaration at enclosure 11.8 prior to commencing an offtake.

5.3 Pre and Post Offtake Briefings

Pre and post offtake meetings are to occur between the Offtake Tanker Master the Offshore Operations Marine Advisor, Pilot/Loadmaster and Production Team Leader in order to ensure all relevant information is conveyed and lessons learnt captured.

6 MOORING OPERATIONS

6.1 Pilot Master Exchange

Offtake Tankers are to complete the Pilot Master Exchange at 11.17 prior to commencing an approach to the Terminal.

6.2 Terminal Pilotage Passage Plan

The pilotage passage plan is located at enclosure 9.1C.17.

Note: prior to arrival at the Ichthys Field, the Offtake Tanker Master shall ensure that the following Terminal requirements have been completed:

- the mooring rope/wire on the starboard forecastle mooring winch drum has been removed and a messenger rope run on,
- both forecastle chain stoppers have been greased, exercised and are free for use
- the hose handling crane is broken out of the cradle and ready to receive the Facility's tanker box

6.3 Offtake Hose

The Offloading Hose is 280m long 500mm in diameter and is of a double carcass design. The offloading hose ship side manifold connection is 400mm.

The connection between the offloading hose manifold and the hose reel is at the stern area on the starboard side of the FPSO poop deck. The hose is to be connected from the FPSO to one of the starboard midships manifolds of the Offtake Tanker.

The FPSO end of the hose is fitted with an emergency release coupling with quick closing valves fitted either side of the coupling to minimise any discharge of condensate to the environment.

Permanent attendance of personnel at the stern of the FPSO is not required during each offloading operation, with the monitoring of hawser and hose tension and other key variables, and emergency shutdown of offloading operations including release of the hose and hawser, performed from the CCR. CCTV is provided to visually monitor the area for any loss of containment during offloading.

Ballasting of the FPSO during cargo offloading is managed using Load Computer inputs into the ICSS.

6.4 Static Tow Operation

Upon the connection of the static towline to the Offtake Tanker's stern and when there is steady weight on the OSV towline, the Offtake Tanker's main engine(s) may be stopped under direction from the Pilot and in consultation with the Tanker Master and Terminal personnel.

It is important that the OSV does not impart excessive weight on the towline prior to stopping the Offtake Tanker's engine(s) to ensure excessive force is not applied to the Terminal mooring system.

The Terminal personnel will remotely monitor the mooring hawser and offtake hose load so as to ensure excessive strain is not imparted upon the FPSO mooring and hose system. The Pilot/Loading Master will monitor hawser loads through the portable laptop Berthing Aid System.

A responsible crew member in continuous radio contact with the Offtake Tanker Bridge / CCR must remain on the Offtake Tanker forecastle at all times whilst the Offtake Tanker is moored to the Terminal. The forecastle watch should report to the Offtake Tanker's CCR at least every hour to check communications and confirm there is adequate weight on the mooring hawser and to alert the Offtake Tanker's CCR, if the tanker is closing towards the stern of the FPSO. The Terminal must be informed immediately if significant weight comes off the mooring hawser or a Jack-knife situation is developing.

If at any time during the OSV static towing operation, the OSV Master, Pilot, Terminal Representative, and/or the Offtake Tanker Master have any cause for concern with regard to the integrity of the tow or the safety of the vessels; either party must immediately alert the other and take whatever action is necessary in order to resolve the situation.

Issued For Use

7 LOADING OPERATIONS

7.1 Cargo Loading Plan

The Offtake Tanker and the Loadmaster are to complete the Cargo Loading Plan at enclosure 11.11 prior to commencing Loading Operations.

7.2 Inspections prior to loading

The Offtake Tanker and the Loadmaster are to complete the Offtake Tanker / Terminal Safety Checklist at 11.12 prior to commencing Loading Operations.

7.3 Testing the ESD Systems

All ESD systems and Tanker High Level Alarms relating to the Condensate Offtake are to be tested prior to commencement of loading operations.

7.4 Inert gas systems

The Inert Gas system on the Offtake Tanker is to be tested and confirmed operational prior to commencement of loading operations.

7.5 Suspension and resumption of cargo operations

Suspension and resumption of cargo operations is to be at the discretion of the Loadmaster, Tanker Master and FPSO OIM.

The Operator may refuse to connect, load or continue to load any Vessel, including a Vessel which has previously been cleared, or may request that such Vessel depart the FPSO, if before, on or after arrival at the FPSO (in the reasonable opinion of the Operator) such Vessel may jeopardise:

- the safety or operation of the FPSO, such Vessel or other Vessels using those facilities; or
- the environment.

7.6 Completion of loading

The Pilot / Loadmaster will be available in the Offtake Tanker's Cargo Control Room at least one hour (60) minutes before the completion of cargo loading operations so as to relay all requests for cargo loading rate changes and stopping of cargo loading operations from the Terminal.

The Terminal will stop loading once the correct quantity is delivered as measured by the volume measuring system.

When the request to stop cargo loading operations has been made, the Terminal Representative will advise when the flow has stopped and the Offtake Tanker's manifold valve can be closed under the direction of the Chief Officer and the Pilot / Loadmaster.

7.7 Manifold draining

Once all draining activities have taken place the Offtake Export Loading Hose valve will be closed and locked by the Terminal Representative. The Terminal Representative will confirm that the valve has been locked in the closed position.

The Offtake Tanker's manifold valve will be confirmed closed and the Offtake Tanker's manifold may then be drained.

7.8 Cargo sampling and Lifter Final Retention Sample

The FPSO is fitted with an automatic in-line sampler operated to continuously sample the Condensate stream during the lifting.

In line samples taken during the offtake are pooled and split into:

1. Testing Sample - 1 x five litre sample to be used for quality determination in the Operator's laboratory
2. Company Retention sample - 1 x five litre sample retained by the Operator, and available for ninety Days and
3. Lifter Final Retention sample - 1 x five litre sample for the Vessel's master.

On completion of the Offtake and at the end of departure operations the Lifters Final Retention Sample will be transferred to the Offtake Tanker via the OSV and receipted for by the condensate tanker's Master.

Issued For Use

8 DEPARTURE OPERATIONS

8.1 Offtake Hose disconnection and Unmooring Procedure

The hose disconnection and unmooring procedure are included in the Master Pilot Exchange document at enclosure 11.17.

8.2 Shipping Documentation

A full set of shipping documents shall be provided to the Condensate Tanker Master prior to departure, unless Early Departure Procedure is invoked.

8.3 Offtake Tanker Environmental Report

Prior to departing the field Offtake Tankers are to complete the Offtake Tanker Environmental Report at enclosure 11.9.

8.4 Offtake Time Sheet

Prior to departing the field Offtake Tankers are to complete the Offtake Tanker Timesheet at enclosure 11.10.

8.5 Early Departure Procedure

The Early Departure Procedure (EDP), in accordance with the Field Lifting Agreement (FLA) shall apply to all Liftings and is a process whereby by the Offtake Tanker Master authorises in writing a representative to sign the Bills of Lading on their behalf allowing the vessel to sail before all documentation is received onboard.

The EDP allows the Offtake Tanker to commence the voyage to the discharge port with the Final Retention Samples on board but without the final documentation.

The Offtake Tanker's authorised representative on completion of the Terminal's laboratory analysis and cargo calculations, will sign and email the following documents to the Offtake Tanker's Master:

1. Bill of Lading;
2. Certificate of quality;
3. Certificate of quantity;
4. Certificate of origin;
5. Cargo manifest;
6. Statement of fact / timesheet;
7. Master's receipt of documents and samples on loading, and
8. Notes of Protest.

Original Documentation is to be provided to the Lifter and Offtake Tanker Master at the first available opportunity.

Each Lifter may, in the event of a dispute regarding quantity or quality of Condensate lifted or deemed to have been lifted, submit a written claim, together with all supporting documents, to the Operator and Offtake Coordinator within ninety (90) Days of the date of the Bill of Lading.

9 EMERGENCY RESPONSE

9.1 Emergency Response Procedures

The FPSO Emergency Response plan S770-AH-PLN-10036 details all of the necessary procedures to be followed in the event of an emergency.

Issued For Use

APPENDIX A: ICHTHYS FIELD CONDENSATE SHIP-SHORE QUESTIONNAIRES - TERMINAL COMPATIBILITY

Section	Item	Ship Specification	Terminal Requirement
Vessel Information	Vessel Name		
	Port of Registration		
	Official Number		
	Call Sign		
	Master's Full Name		For shipping documents
	Delivery date from shipyard:		Maximum age (from delivery date from shipyard) 25 years
	Single or double hull		Double Hull Only. No OBO Vessels
	Deadweight (tonnes)		Maximum ship summer deadweight 120,000 tonne
Vessel Data	Bow to centre manifold (BCM)		Maximum distance bow to centre manifold 140.0 metres
	Arrival Draft F & A in metres		Minimum of one metre stern trim
	Arrival Displacement		Maximum displacement for berthing is 135,000 tonnes
	Displacement of vessel on departure		Ichthys Terminal 150,000 tonne Maximum Displacement
	Departure Drafts F & A in metres (approx.)		Trimmed by the stern or even keel
Manifold Arrangements	Can the vessel accept manifold connection ANSI DN 400?		Manifold connection 400 ANSI 150 flange to connect Terminal Floating Hose
	Distance from manifold flange to hose rail		Provide drawing

Section	Item	Ship Specification	Terminal Requirement
	Does vessel have deck securing points inboard of the hose rail?		Provide drawing with dimensions & SWL's
Cargo & Ballast	Max loading rate for homogenous cargo per manifold connection:		Terminal Max Rate 6,000 m ³ /Hr
	Does the vessel have an operational IG plant?		Terminal Requirement
	On arrival all tanks all tanks to be inerted below 8% Oxygen?		Terminal Requirement
	On arrival all tanks less than 5 parts per million H ₂ S		Terminal Requirement
	Confirm vessel has Segregated Ballast Tanks (SBT)		Segregated Ballast System required
	Confirm status of hydraulic valve system in the event of a black-out. All valves remain 'as is' - or - All valves move to closed position		
	Confirm closing speed in seconds of Tank Main Suction Valves		Terminal Requirement - valve closing speed >26 seconds
	Confirm closing speed in seconds of Manifold Valves		Terminal Requirement - valve closing speed >26 seconds
	When were the Tank High High Level alarms last tested?		Within previous 6 months
Venting	What type of cargo venting system is fitted:		Masthead Venting System required
Mooring Equipment Forward	Provide General Arrangement Plans for Forecastle and After Deck with dimensions & SWL of Mooring Equipment		Terminal Requirement
	How many Bow Chain Stoppers are fitted:		Minimum 2 x 200 metric tonne SWL bow chain stopper/s. Single bow chain stopper arrangement is not acceptable
	Distance between the bow fairlead and chain stopper/bracket:		Maximum distance bow fairlead to chain stopper is 4.0 metres

Section	Item	Ship Specification	Terminal Requirement
	Does the vessel have single or split winch drums		Single preferred - Split Drums must have communicating slot/s
	Is a forecandle winch drum able to receive the full length of hawser messenger rope?		Able to accommodate 150 metre x 32mm messenger and 150 metre x 78mm pick-up rope
Mooring Equipment Aft (For Hold-Back Tug)	What is size / SWL of closed chock and/or fairleads of enclosed type on stern:		Terminal Requirement - Minimum 70 tonnes. Will be used for 'Hold-Back' Tug
	What is SWL of bollard on poop deck suitable for Hold-Back Tug:		Terminal Requirement - Minimum 70 tonnes
Lifting Equipment	Crane description (Number, SWL and location):		Minimum Hose Crane SWL 15 tonne - Derrick or davit hose cranes not allowed
Machinery	Is a bow thruster fitted and operational?		Tonnes bollard pull
	Propeller conventional right hand or other?		
	Number and type of rudder/s		
Access arrangements	Confirmation that vessel can provide and rig their Accommodation & Pilot Ladder in compliance with the IMO recommendations (SOLAS Regulation V/23 & IMO Resolution A.1045(27))		Terminal Requirement
SIRE Inspections	Date of last SIRE inspection:		Sire within last 12 months. SIRE within last 6 months for vessel aged more than 15yrs
Miscellaneous	Provide details of vessel's power (voltage and phase)		Will be used by Inpex Pilot to power Laptop / PPU
	Provide details of vessel's internal power sockets		
	Confirm Lifeboat Capacity - Total Crew plus additional Terminal Staff		
	Confirm Suitable Single Berth Accommodation available for Pilot &		Pilot & Assistant Mooring Master remain onboard throughout the Tanker's

Section	Item	Ship Specification	Terminal Requirement
	Assistant Mooring Master		stay at the Terminal
<i>Note</i>	<i>Vetting is required before 'Clearance' can be considered</i>		

Tanker Arrival Information (E-Mailed to Tanker 24 Hours before Arrival)

Item	Information Required	Detail
1	Name of Tanker	
2	Port of Registration	
3	IMO Number	
4	Master's Name as you wish it to appear on Bills of Lading	
5	Nationality of Officers and Crew	
6	Last Port of Call	
7	Arrival Draft in Metres (Fore and Aft)	
8	Has Free Pratique been granted (Y/N)	
9	International Ship Security Certificate:	
	(a) Number	
	(b) Expiry Date	
	(c) Current Security Level	
10	Cargo Requirements in M3 at 150C	
11	Segregated Ballast to be Discharged at Terminal - Tonnes	
12	Port of Origin of Ballast Onboard	
13	Has Ballast Water Exchange Taken Place at Sea Whilst on Voyage to our Terminal	
	Does vessel have slops on board (Y/N). Quantity onboard and tank no. _____ // _____	
14	Maximum Loading Rate via 1 x 400mm (16") hose	
15	Bridge equipment fully operational (Y/N)	
16	Main engine and ancillary equipment fully operational (Y/N)	
17	Bow thruster (if fitted) fully operational (Y/N)	
18	Forecastle mooring equipment fully operational (Y/N)	

Item	Information Required	Detail
19	Confirm forecastle winch drum and chain stoppers are ready to receive Terminal mooring hawser (Y/N)	
20	Tank ullaging system fully operational (Y/N)	
21	Tank High High Level alarms fully operational (Y/N). Date last tested	
22	Pumproom fans fully operational (Y/N)	
23	Midships hose crane fully operational (Y/N). What is the Working Load Limit (WLL)?	
24	Is vessel able to put maintain positive accommodation air conditioning pressure on full recirculation (Y/N)	
25	Are All Tanks Inerted below 8% Oxygen (Y/N). What is the O2 percent in cargo tanks?	
26	Are All Tanks less than 5PPM H2S?	
27	Is vessel's IG system fully operational (Y/N)	
28	Can Vessel Carry Out Closed Loading (Y/N)	
29	Is vessel able to vent via Mast Riser (Y/N)	
30	Is vessel fitted with individual tank vapour locks and able to closed load/ullage (Y/N)	
31	What is the closing speed time of cargo hydraulic valves? (must be more than 16 seconds)	
32	Is the Stbd Side Manifold OCIMF Standard	
33	Estimated Departure Draft in Metres (Fore and Aft)	
34	Next Port of Call	
35	Discharge Port of Condensate	
36	Confirm Electrical Voltage & Socket Type Onboard	
37	Confirmation that vessel can provide and rig their Accommodation & Pilot Ladder (Stbd Side) in compliance with the IMO recommendations (SOLAS Regulation V/23 & IMO Resolution A.1045(27))	

APPENDIX B: PILOT BOARDING ARRANGEMENTS

REQUIRED BOARDING ARRANGEMENTS FOR PILOT

In accordance with SOLAS Regulation V/23 & IMO Resolution A.1045(27)

INTERNATIONAL MARITIME PILOTS' ASSOCIATION

H.Q.S. "Wellington" Temple Stairs, Victoria Embankment, London WC2R 2PN Tel: +44 (0)20 7240 3973 Fax: +44 (0)20 7210 3518 Email: office@impahq.org

This document and all IMO Pilot-related documents are available for download at: <http://www.impahq.org>



RIGGING FOR FREEBOARDS OF 9 METRES OR LESS

HANDHOLD STANCHIONS
Min. Diam. 32mm
Min. 120cm Above Bulwark

MAN-ROPES (without knots)
Min. Diam. 28mm
Max. Diam. 32mm
IF REQUIRED BY THE PILOT

SIDE ROPES
Min. Diam. 18mm

ALL STEPS
Must rest firmly against ship's side

SPREADER
Min. 180cm Long

MAXIMUM 9 STEPS
Between spreaders

Min. 40cm
31-35cm

5th STEP
From bottom must be a spreader

6 METRES
unobstructed ship's side

Height Required by Pilot

COMBINATION ARRANGEMENT FOR SHIPS WITH A FREEBOARD OF MORE THAN 9 METRES WHEN NO SIDE DOOR AVAILABLE

PILOT LADDER
Must extend at least 2 metres above lower platform

Ladder must be firmly attached to ship's side 1.5 metres above accommodation platform

Maximum 45° slope should lead aft

Lower platform horizontal

The lower platform shall be a minimum of 5 metres above the sea

Recommended 9 metres freeboard mark

Accommodation ladder should be secured to ship's side (Using eyespade, magnetic or pneumatic system)

Lifebuoy with self-igniting light

Bulwark & Pilot ladder secured to deck strong points

PILOT LADDER WINCH REEL

NO! No shackles, knots or splices

NO! The steps must be equally spaced

NO! The steps must be horizontal and chocks under the steps must be tightly secured

NO! Spreaders must not be lashed between steps

NO! Side ropes must be equally spaced

NO! The steps should not be painted, dirty or slippery

NO! Loops and tripping lines present a tripping hazard and foul the Pilot Launch

Handhold stanchions rigidly secured to deck

Responsible Officer in contact with bridge

Lifebuoy with self-igniting light

Bulwark & Pilot ladder secured to deck strong points

PILOT LADDER WINCH REEL

All pilot ladder winch reels should have a means of prevention from being accidentally operated.

The brake and lock must be operative on manually operated winches.

Power winches must have an operative safety device to lock the winch in position.

PILOT LADDER WINCH REEL

Ship's side doors used for transfer should not open outward

APPENDIX C: ENCLOSURES

C.1 INPEX FPSO Offloading Meeting

This checklist provides draft information for the FPSO Offloading Meeting Agenda. The meeting takes place onboard the FPSO before the Export Vessel arrives at the terminal. The Production Supt. shall conduct and chair this pre-transfer meeting.

The purpose of this meeting is to verify the FPSO readiness to safely manage the transfer operation, agree on the proposed transfer plan, discuss the Export Vessel status and characteristics and to outline any actions required following unplanned incidents.

Information for this meeting is contained in the following documents:

Specific Delivery Schedule

Offtake Coordinator Loading Instructions for this Cargo Number

EC System (available to CCR Operator)

Tanker responses to the Q.88, Terminal Specific & Pre-Arrival Questionnaires

FPSO System Procedures – S-242 Condensate Export and Metering - Condensate Offloading & S-242 Condensate Offtake and Metering - Berthing and Un-berthing Offtake Tanker

X-060-A1-MAN-60002 Offshore Marine Terminal Handbook

Confirmation from the OSV (Go Koi) that she is operational for the export operation

The table at the bottom lists the attendees for the offloading meeting. The meeting shall include but not be limited to the following topics:

Production Ops / Offtake readiness to commence transfer operations	
Any process or system limitations	
Any additional checks / tests required – frequency & impact on transfer operations	
Thruster Status	
PLM description of the inbound vessel	
Type / Size / draft / from / to	
Compatibility – Mooring / Manifolds / Engines	
ETA at Pilot Station	
Inbound Passage – time expected at berth	
Cargo Information	
Cargo Number:	
Cargo onboard (ROB)	
Cargo to load	
Tanker Cargo Capacity	
Estimated loading time (hours)	
Early Departure Procedure (EDP) agreed	
Export Operations	
Hose operations	
Hawser operations	
Static Tow	
General discussion on maintenance of FPSO systems and Emergency Stop / Disconnect systems integrity	
Production Supt. - Condensate Transfer Plan including:	
Provision of the Product Safety Data Sheet (SDS)	
Loading rate adjustments and loading completion	

requests initiation - any and all unplanned reductions in loading rate, or stoppages must be communicated to the vessel / CCR as soon as possible. Under no circumstances shall the transfer rate be increased without prior agreement from the vessel / CCR and PLM.	
EC Status (EC System on-line or hard-copy cargo document available)	
Discussion regarding Survey / Gauging / Cargo Figures requirements	
Current and forecast weather and tidal conditions in relation to Berth Operating Criteria and a discussion regarding any proposed mitigations/plans for any forecast events such as but not limited to:- Tandem Alignment - FPSO, Vessel, OSV & PLM to maintain close watch Adverse Weather - may require hose disconnection / berth departure Solitons - Maintain radar watch - FPSO	
Expected Simultaneous Operations (SIMOPS) including potential NOPSEMA inspections, etc.	
Discussion regarding the Commonwealth Maritime Transport and Offshore Facilities Security Act 2003 (MTOSFA) and the Field Security Plan. Confirmation Security Level of the Terminal and of the vessel. If required a Security declaration to be signed by Master and FPSO PFSO.	
Discussion regarding Port and Reporting compliance	
Incident reporting	
The Vessel's emergency preparedness.	

Offloading Meeting Required Attendees

Required Attendee	Representing	Meeting Role
INPEX FPSO Production Supt. or Delegate	FPSO Production Operations	Facilitate co-ordination of FPSO activity
INPEX FPSO Operation's - ATL Offloading	FPSO Production Operations	Facilitate co-ordination of FPSO activity
Pilot Loading Master	Inpex Operations / Fendercare	Facilitate co-ordination of Export Tanker / OSV activities
Assistant Mooring Master / Cargo Surveyor	FPSO Operations / Intertek	Mooring / Hose Operations / Represent Lifter and Buyer for gauging, sampling & cargo figures
FPSO CCR Technician	FPSO Operations - Cargo Plan Management / EC	
Inpex Marine Operations Advisor (Telephone)	Marine Advice - Tanker compatibility / vetting matters as required	Marine Operations
Cargo Number ____ 2018 - Personnel Transferring to Tanker		

Role	Name	Comment
Pilot Loading Master		
Fendercare Supt – Senior Pilot Loading Master		
Assistant Mooring Master - Surveyor		
Inpex Marine Advisor		

Issued For Use

C.2 Pre-Loading Meeting Agenda

This checklist provides the necessary information for a Pre-Loading Meeting Agenda. The meeting takes place onboard the Vessel after arrival at the terminal and prior to commencement of loading.

Vessel: _____

Master's Name: _____

Cargo Number: _____

Arrival Date: _____

Items to be confirmed: For Condensate Tankers

Vessel tank status arrival					
1S	2S	3S	4S	5S	Stbd. Slop
1C	2C	3C	4C	5C	
1P	2P	3P	4P	5P	Port Slop

Pre-Loading Meeting Agenda	
Agreed loading quantity (m3)	
Quantity on board at arrival (m3)	
Full loaded cargo tank capacity (m3)	
Estimated loading time (hours)	
Load/ballasting plan and stability information provided to Terminal	
Early Departure Procedure (EDP) agreed	
Manifold connections Ship and Terminal	
Confirm focsle deck and CCR watch is in place	
1 x 16" Loading Hose connected to starboard manifold	
Manifold connection – sound - Hose supported & secure NB: Re-Check Camlocks are all tight before confirming 'All	

Ready To Start Cargo Transfer'	
Initial Safety Checklist completed	
What is the closing speed time of cargo hydraulic valves? (should be more than 16 seconds)	
Initial loading rate required	
Maximum loading rate (m3/hr)	
Topping off loading rate (m3/hr) Notice to reduce loading rate (30 mins)	
Vessel or FPSO stop?	
Emergency stop procedure agreed	
Confirm that Terminal Regulations require continuous 'Manifold & Focsls Head' Watches.	
Radio communications tested.	
VHF Radio on Channel ____ during loading and VHF Channel ____ for manoeuvring	
ILNG UHF Radio on Channel _____ during loading	
Terminal to provide weather reports to Vessel at pre- and post- load meetings and whenever else required.	
Any incident or protest to be reported to Terminal Representative immediately.	
Any Vessel planned maintenance whilst at the Terminal?	
Status of Vessel's engines	
Vessel requires _____ minutes after hose disconnection for engine warming?	

Master or Deputy: _____

Terminal Representative: _____ Date: _____

C.3 Post Loading Meeting Agenda

Vessel: _____

Cargo Number: _____

Date of Departure: _____

Items to be confirmed:

EDP authorisation issued to Shipping Agent	
Port Timesheets complete with agreed times	
Notes of Protest issued and signed for receipt (Terminal/Vessel)	
Remarks on cargo berthing and/or loading operations, if any.	
Cargo loading figures agreed	
Observations from the safety inspections discussed	
Shipping Documents completed (if not EDP)	
Pilot on board time for departure	
Procedure of disconnection of gangway and cables agreed	
Time disconnection of gangway and cables agreed	
Departure time agreed and Terminal personnel available	
Towage services notified	
Completed Terminal vessel inspection report provided to Vessel	
UHF Radio returned	
Updated weather information by the Terminal	
Confirm discharge port and ETA	
Incident/accidents discussed and noted	
Others	

Master or Deputy: _____

Terminal Representative: _____

Date: _____

Original: Ship / Copy: ILNG

C.4 FPSO Terminal Conditions of Use

The FPSO Terminal Conditions of Use are set out below. Please confirm acceptance printing out the Deed Poll below as a separate document, signing it and returning it to INPEX.

THIS DEED POLL IS DATED: ___ / ___ / 20___

GIVEN BY:

(A) **THE VESSEL INTERESTS** (AS DEFINED BELOW); and

IN FAVOUR OF:

(B) **PROJECT INTERESTS** (AS DEFINED BELOW)

IN RELATION TO THE FOLLOWING VESSEL:

MV _____ (the "Offtake Tanker")

IT IS AGREED AS FOLLOWS:

1 DEFINITIONS AND INTERPRETATION

1.1 Definitions

In this Deed, unless the context otherwise requires:

Affiliate means in respect of any Person (the 'Relevant Person'), a person that directly or indirectly controls or is controlled by the Relevant Person or is, together with the Relevant Person, under the common direct or indirect control of another Person, for which purpose 'control' shall mean beneficial ownership of fifty percent (50%) or more of the voting shares of a company or other entity or of the equivalent rights to determine the decisions of such a company or other entity.

Claim means any claim, right, action, proceeding, demand or entitlement of any kind and includes a right, proceeding, demand or entitlement to be compensated or indemnified (in whole or in part) for or by way of loss, obligation of indemnity or contribution, damage, expense or liability however arising (whether in contract, tort, under statute or otherwise).

Condensate means any mixture of Hydrocarbons separated and/or condensed from reservoir Hydrocarbons (or Hydrocarbons produced from the reservoirs) produced at the Ichthys Field.

Day means a period of twenty four (24) consecutive hours starting at 00:00 hours:

- (a) in the case of obligations related to the FPSO, UCT + 8 hours; and
- (b) in any other case where the context so requires, the time zone relevant to the particular location.

Deed means this document.

Facility Services means permitting access to the FPSO and all and any services (with or without goods or other property) of any description (whether compulsory, voluntary or otherwise) provided or performed (whether or not for consideration) by, or on behalf of, the Project Interests at, on or about the FPSO and its approaches and/or the Offtake Tanker, or within 3 nautical miles of the FPSO, directly or indirectly in connection with the production and loading of Condensate from the FPSO, including the services provided by the Service Providers (including the OSV), pilotage, pilot transportation, towage, tug services, navigation, berthing, mooring, loading, communications, watch or other services, assistance, direction, advice, instruction or other conduct whatsoever.

Fault means a breach of duty in negligence or any other tort, in contract, under statute or otherwise.

FPSO means the floating offshore production, storage and offloading facility processing Hydrocarbons from the Ichthys Field.

FPSO OIM means a Person qualified in terms of the Operator's requirements, provided by the Operator as the offshore installation manager of the FPSO, and has overall responsibility for the FPSO and the Persons on board the FPSO.

Government means the government of Australia, Western Australia, and any relevant local Governmental Authority in Australia that has legal authority over the Parties or all or part of the FPSO.

Governmental Authority means in respect of any country, any national, regional, state, municipal, local or other government, any subdivision, agency, commission or authority, including any port authority, of it or any quasi-governmental organisation within it.

Hydrocarbons means all hydrocarbon substances, all gaseous hydrocarbons (including wet gas, dry gas and residue gas and any processed forms of them such as liquefied natural gas) and all hydrocarbons which normally exist in liquid state at atmospheric pressure (including liquefied petroleum gas, oils and Condensates).

Ichthys Field means the three dimensional polygon enclosing the discovered Hydrocarbon pools located at WA-50-L and WA-51-L.

Ichthys JOA means the Joint Operating Agreement between INPEX Ichthys Pty Ltd and Total E&P Ichthys, and their permitted assigns, successors and assignees, dated 29 June 2011, as amended from time to time.

Incident means any occurrence, or series of occurrences having the same origin, arising out of or relating to the Offtake Tanker using the FPSO, in which there is any one or more of:

- a. loss of or damage to the FPSO or Offtake Tanker or OSV;
- b. loss or damage, other than to the FPSO or Offtake Tanker or OSV, caused or contributed to by the FPSO;
- c. loss or damage, other than to the FPSO or Offtake Tanker or OSV, caused or contributed to by the Offtake Tanker;
- d. loss or damage, other than to the FPSO or Offtake Tanker or OSV, caused or contributed to by the OSV;

- e. an escape or discharge of oil, oily mixture or other pollutant:
 - i. from the Offtake Tanker;
 - ii. within 3 nautical miles of the FPSO; or
 - iii. which interferes with the normal operation of the FPSO or OSV; and
- f. an obstruction or danger affecting or interfering with the normal operation of the FPSO, the Offtake Tanker or OSV.

Joint Venturers means the relevant joint venturers from time to time having an interest in the FPSO pursuant to the Ichthys JOA, as amended, and the successors in interest of those joint venturers or the assignee of any interest of those joint venturers.

Joint Venturers' Personnel means the directors, officers, employees, servants, secondees, agents and contractors of the Joint Venturers.

Law means any statute, regulation, order, judgment, rule, subordinate legislation or other document enforceable under any statute, regulation, order, judgment, rule or subordinate legislation.

Offshore Terminal Handbook means the current version of the FPSO operating handbook as prepared by the Operator.

Offtake Tanker means a ship employed for the purpose of transporting Condensate from the FPSO and otherwise identified in this Deed.

Operator Personnel means the directors, officers, employees, servants, secondees, agents and contractors of the Operator including the Pilot, Load Maser and FPSO OIM.

Operator Property means any plant and equipment owned by or under the care and control of the Operator.

OSV means the offshore support vessel rendering services to the FPSO and Offtake Tanker.

OSV Crew means the officers and crew of the OSV including the OSV Master.

OSV Master means the master of the OSV.

Operator means INPEX Operations Australia Pty Ltd as the delegated operator and agent of the Joint Venturers.

Party means a Person having contractual legal rights and/or contractual legal obligations under this Deed.

Person means any individual, corporation, partnership, trust, unincorporated organisation or other legal entity, including any Governmental Authority.

Pilot and Loading Master means a Person qualified in terms of the Operator's requirements and provided by the Operator for the manoeuvring and loading of the Offtake Tanker.

Project Interests means the Operator and its Affiliates, Operator Personnel, the Joint Venturers and their Affiliates, the Joint Venturers' Personnel and Service Providers.

Service Providers means vessels and their owners (including any direct, indirect and part owner of that vessel and any disponent owner of any tier), masters, officers and crew rendering services to the FPSO and / or Offtake Tanker (including the OSV and the OSV Crew).

Tanker Master means the Person so designated in the ship's official log book on board the Offtake Tanker.

Terminal Operating Procedures means the operating procedures set out in the Offshore Terminal Handbook issued from time to time by the Operator or any Laws applicable to the activities in or around the FPSO.

Third Party means any Person other than the Project Interests and Vessel Interests.

Vessel Interests means, jointly and severally, the Offtake Tanker, her owners, charterers (time, voyage, demise or otherwise), operators, and the owners of cargo and/or bunkers aboard the Offtake Tanker and Vessel Personnel.

Vessel Personnel means the respective directors, officers, employees, servants, secondees, agents and contractors of each of the Vessel Interests (including the Tanker Master, officers and crew of the Offtake Tanker), and all Persons employed, engaged or present on an Offtake Tanker authorised by the Operator to use the FPSO.

2 INTERPRETATION

In this Deed unless otherwise specified, reference to:

- a. 'includes' and 'including' shall mean including without limitation;
- b. words denoting the singular shall include the plural and vice versa, and words denoting any gender shall include all genders;
- c. a Party shall include the successors and permitted assigns of that Party;
- d. clauses are to recitals, clauses or schedules of this Deed;
- e. where the Deed, expressly or impliedly:
 - i. allow the Operator a discretion as to whether or not to do any act or thing of any kind, or as to how it may be done; or
 - ii. confer on the Operator a power of determination, or a right of opinion, satisfaction, or the like,
 - iii. that discretion, power, or right of the Operator is absolute unless the Deed state otherwise;
- f. wherever in this Deed a Party's consent, approval or agreement is required to be not unreasonably withheld, such obligation shall include but not be limited to the obligation of such Party to not unreasonably delay giving the relevant consent, approval or agreement;
- g. wherever in this Deed a Party is required to exercise its endeavours to do something or refrain from doing something, without prejudice to the general meaning of such expressions or undertakings, such Party shall not be in breach of its obligations to the other Party to the extent its actions are limited by its need to comply with its contractual and legal obligations, provided that such Party has (where reasonable to do so) used its reasonable endeavours to obtain any necessary waiver of such obligations;
- h. an agreement (other than this Deed) includes that agreement as amended, supplemented, novated or replaced from time to time;

- i. a statute (including any subordinate legislation), code or guideline include that statute, code or guideline as from time to time modified or re-enacted or consolidated whether before or after the execution date of this Deed;
- j. any authority, association or body whether statutory or otherwise shall, if any such authority, association or body ceases to exist or is reconstituted, renamed or replaced or its powers or functions are transferred to any other authority, association or body, be deemed to refer respectively to the authority, association or body established or constituted in lieu thereof or as nearly as may be succeeding to the powers or functions thereof;
- k. Project Interests includes any one or more of them as the context may permit or require, and a reference to Vessel Interests includes any one or more of them as the context may permit or require; and
- l. any Person also imports his, her or its legal personal representatives, administrators, successors and permitted assigns.

3 HEADINGS AND CONFLICTS

The headings in this Deed are inserted for convenience only and shall not affect the construction of this Deed.

4 PERIODS OF TIME

- a. In the computation of periods of time from a specified day or Day to a later specified day or Day, the word 'from' means 'from but excluding' and the words 'until' and 'to' mean 'to and including'.
- b. Any provision or stipulation that an action may or shall be taken within a specified number of days or Days shall mean that such action may or shall be taken within the number so specified starting at 0:00 hours on the day or Day on which the right or obligation to take such action arose.
- c. All dates and periods of time shall be determined by reference to the Gregorian calendar.

5 CAPACITIES

- a. The Vessel Interests agree that the Operator acts as agent for and on behalf of each of the Joint Venturers severally. This Deed will be read and construed accordingly. Notwithstanding the above:
 - i. the Vessel Interests agree to deal with the Operator in relation to the due performance of the Deed;
 - ii. the Operator will have no liability in connection with this Deed;
 - iii. the Joint Venturers shall be entitled to the rights created by this Deed;
 - iv. the rights, obligations and liabilities of each Joint Venturer is several (and not joint, nor collective, nor joint and several) in proportion to its interest in the FPSO;
 - v. Vessel Interests shall not commence proceedings against the Joint Venturers, save for the enforcement of an arbitration award or court judgment obtained against Operator as agent for the Joint Venturers;
 - vi. Operator may enforce the Deed for the Project Interests as well as for itself. For that purpose the Operator may commence proceedings in its own name to enforce all obligations and liabilities of Vessel Interests and to make any Claim which the Project Interests may have against Vessel Interests; and

- vii. losses, damages, costs (including legal costs on a solicitor and client basis) and expenses of the Project Interests may be recovered as part of the losses, damages, costs (including legal costs on a solicitor and client basis) and expenses recoverable by Operator pursuant to the Deed or otherwise.
- b. If the Vessel Interests comprise more than one Person or body corporate, the Deed binds each such Person or body corporate (together with their respective successors and permitted assigns) jointly and severally and will be read and construed accordingly.

6 APPLICATION

- a. Notwithstanding any other agreement, and notwithstanding any rights that each Party may have under the applicable law or any other law that may govern the determination of liability among the Parties in respect of an Incident, the liability of the respective Project Interests and Vessel Interests in respect of any Incident is determined and limited exclusively in accordance with the terms and conditions set out in this Deed. In the event of any inconsistency between this Deed and any other agreement or applicable law, this Deed shall prevail.
- b. This Deed commences on the date of its execution and continues in full force and effect until it is earlier terminated by consent among the Parties. This Deed applies to any Incident which occurs during that period. After that period, this Deed remains in force until the discharge of all obligations hereunder which arise during that period. Termination of this Deed shall be without prejudice to the rights and liabilities of the Parties accrued prior to or as a result of such termination. Any provisions of this Deed which are necessary for the exercise of such accrued rights shall survive expiry of this Deed to the extent so required.

7 PERFORMANCE OF FACILITY SERVICES

- a. The Operator's provision or performance of the Facility Services is in consideration of, and is subject to, the Vessel Interests' acceptance of the terms and conditions set out in this Deed.
- b. The Operator shall charge the Vessel Interests the Terminal Fee (as contained in the Terminal Handbook) for the provision or performance of the Facility Services. Vessel Interests must pay the Terminal Fee within thirty (30) Days of receipt of an invoice from the Operator.
- c. The performance of an obligation of any kind by the Vessel Interests must be carried out at the Vessel Interests' cost unless the Deed states otherwise.
- d. If the Operator makes any payment or incurs any cost of any kind or otherwise incurs any liability in meeting any obligation of the Vessel Interests pursuant to the Deed, the payment so made or the cost so incurred becomes a debt then due and owing by the Vessel Interests to the Operator.
- e. Notwithstanding any other provision of this Deed, if any member of the Project Interests is subject to any implied condition or warranty pursuant to the Australian Consumer Law as amended ("Consumer Law") in connection with the supply of Facility Services, the Vessel Interests agree that the Project Interests liability is limited to the breach of any such implied condition or warranty that cannot be excluded, restricted or modified, to the supplying of the applicable Facility Service again or the payment of the cost of having the applicable Facility Service supplied again, as determined by the Operator.

8 OPERATIONS

- a. Vessel Interests acknowledge having received or had access to a copy of, and shall at all times observe, perform and comply with the provisions and requirements of, the current edition of Offshore Terminal Handbook.
- b. Vessel Interests acknowledge and agree that the Project Interests provide and perform Facility Services strictly subject to this Deed. Vessel Interests shall at all times observe, perform and comply with this Deed, the requirements of the Offshore Terminal Handbook and all relevant OCIMF requirements and shall indemnify and at all times keep fully and effectually indemnified the Project Interests against all and any obligations, liabilities, losses, damage, costs or expenses whatsoever and howsoever sustained, incurred or suffered directly or indirectly as a consequences of failure to so observe, perform and comply. For the avoidance of doubt, the actions and omissions of all personnel (including the OSV Crew) employed or contracted by the Project Interests in connection with the performance of the Facility Services are deemed to be the actions and omissions of the Vessel Interests for the purposes of this clause.
- c. The Vessel Interests must conduct all operations at and around the FPSO safely and expeditiously, and must vacate the FPSO as soon as practicable after the provision of the Facility Services is completed. The Vessel Interests must comply, and must ensure that all Vessel Personnel comply, with the Terminal Operating Procedures.
- d. The Vessel Interests agree that the Operator may withhold the commencement of, suspend or terminate the provision of the Facility Services and is entitled to take any other such action as the Operator thinks fit including requiring the removal of any Offtake Tanker from the FPSO, ordering the Offtake Tanker to leave the berth and to prohibit an Offtake Tanker from berthing or reberthing (by direction of the FPSO OIM, Pilot and Loading Master or other authorised representative of the Operator), where in Operator's opinion:
 - i. such action is required for the safety of the FPSO, the Offtake Tanker, vessel of any Service Provider (including OSV), the Operator Personnel, the Joint Venturers' Personnel, the Vessel Personnel, the crew of the Service Providers (including the OSV Crew) or any other vessel or any Third Party;
 - ii. there is any breach or likely breach of this Deed or the Terminal Operating Procedures or any other part of the Offshore Terminal Handbook;
 - iii. there are defects in the Offtake Tanker or the Offtake Tanker's equipment, manning or operations which, present a hazard to FPSO or operations relating to the FPSO, the Offtake Tanker, vessels of the Service Providers (including the OSV), the Operator Personnel, the Joint Venturers' Personnel, Vessel Personnel, the crew of the Service Providers (including the OSV Crew) or any other vessel or any Third Party;
 - iv. the Tanker Master wishes to undertake repairs to the Offtake Tanker;
 - v. the Offtake Tanker is not, or is likely not to be, in all respects fit to berth or load a the FPSO;
 - vi. the Offtake Tanker fails to make satisfactory use of the Facility Services resulting in an unacceptable constraint on the Operator's operations;

- vii. it is necessary due to the landing or departure at the FPSO or Offtake Tanker of a helicopter; or
 - viii. weather, safety or security conditions exceed, or are likely to exceed, normal operating limits.
- e. The Vessel Interests acknowledge and agree that the Project Interests (in whatever capacity its members may be acting) is not liable for any costs, losses, damage or liability incurred by the Offtake Tanker or other Vessel Interests as a result of a refusal to load all or part of a nominated cargo, delay or suspension of loading, or a requirement to vacate the FPSO or other action arising from this Deed, and the Vessel Interests release and indemnifies the Project Interests from such costs, losses, damage or liability.
 - f. In all circumstances the Vessel Interests remain solely responsible for the safety, condition, operations and proper navigation of the Offtake Tanker and her appurtenances, property and cargo, including pilotage, towage, navigation, berthing, mooring and unmooring, manoeuvring (including to transfer personnel and/or equipment via an OSV or other means), connecting and disconnecting of the FPSO's floating hose to the Offtake Tanker's manifold, connecting and disconnecting of the tow lines to an OSV, ballasting, prevention and control of pollution or contamination, pollution or contamination remediation, and safety.
 - g. The Vessel Interests acknowledge and agree that all personnel (including the OSV Crew) employed or contracted by the Project Interests in connection with the performance of the Facility Services are supplied upon the condition that the presence of those personnel in or about the FPSO or the Offtake Tanker or OSV and otherwise in connection with the performance of Facility Services in no way relieves the Vessel Interests of any obligation, responsibility or liability in connection with the safety, security, condition, operations or proper navigation of the Offtake Tanker or its appurtenances and cargo. Subject to the indemnities by the Vessel Interests in favour of the Projects Interests in this Deed which includes such personnel referred to in the foregoing (including the indemnities in clauses 4.2, 6.1 and 6.2), all such personnel referred to in the foregoing are supplied upon the condition that in so providing or performing Facility Services, each Person is a servant of the Offtake Tanker in every respect and not the servant or contractor of the Project Interests.
 - h. The Vessel Interests acknowledge and agree that the no warranty or representation (express or implied) as to the safety or suitability or otherwise of the FPSO or its approaches or the Facility Services is given by the Operator (on its own behalf or on behalf of the other Project Interests) in respect of the same.
 - i. If the Offtake Tanker or part of the Offtake Tanker sinks, becomes a constructive loss, or otherwise becomes, in the opinion of the Operator, an obstruction or danger to any part of the FPSO, the approaches to it, or any subsea installations related or connected to it, and the Vessel Interests fail for any reason to remove that obstruction or danger within the time required by the Operator or a competent authority, the Vessel Interests acknowledge and agree that the Operator or such competent authority may take all necessary action to remove the obstruction or danger at the sole risk, cost and expense of the Vessel Interests and that cost and expense, and any loss or damage suffered by Project Interests, will be recoverable from the Vessel Interests by the Operator as a debt presently due, owing and payable to Project Interests.

9 RIGHT TO BOARD

The Vessel Interests acknowledge and agree that the Pilot and Loading Master has the right at any time to board and remain on board any Offtake Tanker using the FPSO to ensure this Deed and the Terminal Operating Procedures are being observed. The Tanker Master must, on request, immediately produce any certificate or other documents reasonably requested by the Pilot and Loading Master for inspection for the purposes of this clause 5.

10 LIABILITIES AND INDEMNITIES

- a. The Vessel Interests acknowledge and agree that none of the Project Interests (regardless of the capacity in which they may be acting) shall be responsible for or liable to (whether in contract, tort or by statute or otherwise) the Vessel Interests or any other Person whatsoever in respect of, any death, personal injury or illness of any Person, loss or damage to any property of any Person (including particularly the Offtake Tanker and her property or cargo), or delay of any description, arising directly or indirectly (and whether recklessly, negligently or otherwise) in consequence of provision or performance of (or failure to provide or perform) any Facility Services, and the Vessel Interests hereby agree to protect, defend, indemnify and hold harmless the Project Interests accordingly, regardless of Fault or cause on the part of the Project Interests or otherwise.
- b. Vessel Interests shall be responsible for, and shall indemnify, the Project Interests for all liability (including contractual, tortious, statutory and other liability) for pollution or contamination (including without limitation any crude oil, bunkers or other fluids, materials or substances of whatever description) or the direct or indirect consequences of the same (including, without limitation, death, injury or illness of any Person, loss or damage to property, statutory and civil liability for penalties and/or damages, liability to all Persons having a Claim against the FPSO, OSV, the Project Interests and/or the Offtake Tanker resulting directly or indirectly from pollution contamination or its consequences) if and to the extent that such pollution or contamination is either caused directly or indirectly by the Vessel Interests, whether negligently or otherwise, or if the pollution or contamination occurs as a result of escape (for whatever reason) of oil or any other pollutant from any point on the Offtake Tanker. For the avoidance of doubt, the actions and omissions of all personnel (including the OSV Crew) employed or contracted by the Project Interests in connection with the performance of the Facility Services are deemed to be the actions and omissions of the Vessel Interests for the purposes of this clause.
- c. The Vessel Interests acknowledge and agree that the Project Interests are not liable in contract or tort (including without limitation negligence) or otherwise howsoever, as a result of any act or omission in the course of or in connection with this Deed, for or in respect of:
 - i. any indirect, incidental or consequential or exemplary loss or damage;
 - ii. any loss of revenue or profits; or
 - iii. any loss of production, loss of bargain, loss of goodwill or loss of contract.

11 LIEN

The Vessel Interests acknowledge and agree that the Operator has a lien on the Offtake Tanker, and her cargo, freight and appurtenances for all salvage, debts, losses or damages or other Claims arising out of the Offtake Tanker's use of Facility Services.

12 WAIVER

Regardless of any Person's Fault, Vessel Interests waive in favour of Project Interests any rights, entitlement or other Claim to limit their liability under this Deed with respect to an Incident from which they might otherwise benefit under any applicable law, including any statute, the Convention on Limitation of Liability for Maritime Claims 1976, the Limitation of Liability for Maritime Claims Act 1989 (Cth) or any other convention now or hereafter enacted or adopted. Part 1F of the Civil Liability Act 2002 (WA) is excluded from operation with respect to any dispute, action or other Claim whatsoever brought by any Party against another arising out of or in connection with this Deed.

13 LIMITS OF PROJECT INTERESTS' LIABILITY

- a. any liability of Project Interests to Vessel Interests hereunder is several;
- b. the aggregate liability of Project Interests to Vessel Interests under this Document in respect of any one Incident, howsoever arising, is limited to one hundred and fifty million United States Dollars (US\$150,000,000) or such greater amount as the Parties may mutually agree upon in the future.
- c. payment of the amount specified in clause 9.2 or the amount of any greater limit, as provided for in that clause, to any one or more of Vessel Interests in respect of any one Incident is a complete defence to any suit, demand or other Claim relating to that Incident made by Vessel Interests against Project Interests.

For the purposes of this Deed, but not for any other purpose, the property of any one or more of Vessel Interests is deemed to be the property of all of them.

14 LIMITS OF VESSEL INTERESTS' LIABILITY

- a. The liability of Vessel Interests to Project Interests hereunder is joint and several.
- b. The aggregate liability of Vessel Interests to Project Interests under this Deed in respect of any one Incident, howsoever arising, is limited to one hundred and fifty million United States Dollars (US\$150,000,000) or such greater amount as mutually agreed between the Parties.
- c. Payment of the amount specified in clause 10.2 or the amount of any greater limit, as provided for in that clause, to any one or more of Project Interests in respect of any one Incident is a complete defence to any suit, demand or other Claim relating to that Incident made by Project Interests against Vessel Interests.
- d. For the purposes of this Deed, but not for any other purpose, the property of any one or more of Project Interests is deemed to be the property of all of them.

15 INSURANCE

The Offtake Tanker owners and charterers shall keep the Offtake Tanker entered as protected with a P&I Club which is a member of the International Group of P&I Clubs. The Offtake Tanker owners and charterers shall pay all premiums, fees, dues and other charges of that P&I Club and comply with all of its rules, terms and warranties in accordance with normal industry practice. The Offtake Tanker owners and charterers shall keep Project Interests informed of the identity and business address of the P&I Club with which the Offtake Tanker is entered as protected, the amount, including the amount of any greater limit, as provided for in clause 10.2, of that protection and such information as is available and appropriate on the terms of that protection.

16 THIRD PARTY CLAIMS

- a. Subject to clause 12.2, any Australian legislation that is equivalent of the Contracts (Rights of Third Parties) Act 1999 of the United Kingdom (such as Property Law Act 1969 of Western Australia) does not apply to this Deed and all of the rights granted to Third Parties under that Australian legislation are hereby excluded.
- b. The provisions of clause 12.1 do not apply to any Person to the extent any such Person is entitled to insurance, defense, release, limitation of liability or indemnity protection under this Deed (such as a Person who is included in "Project Interests" and "Vessel Interests" as applicable but who is not a Party to this Deed) and each such Person may, subject to clause 12.3, enforce any such entitlement in accordance with the relevant Australian legislation.
- c. The Vessel Interests may not amend, vary, supplement or terminate this Deed without the consent of the Operator.

17 GOVERNING LAW

This Deed and any non-contractual obligations arising out of or in connection with it are governed by the laws of Western Australia. The Vessel Interests hereby submit to the jurisdiction of the courts of Western Australia and of any court that may hear appeals from any of those courts, from any proceedings in connection with this Deed.

THIS DEED POLL IS ENTERED INTO ON THE DATE SET OUT ABOVE**EXECUTED AS A DEED POLL**

by the Master of the Offtake Tanker)
 who states that he is authorised to sign)
 this Deed for and on behalf of)
 THE VESSEL INTERESTS)
 in the presence of:)

 Signature of Master

 Signature of Witness

 Name of Master

 Name of Witness

C.5 Acceptance of Terminal Conditions of Use

FPSO Ichthys Venturer

Date...../...../.....

The Master

MV.....

Dear Captain,

Prior to offtake operations commencing it is expected that you have read and accepted the Ichthys Offshore Terminal Conditions and that you and your crew comply with those conditions whilst your vessel is visiting the Terminal.

By signing below you confirm that you have read the Ichthys Offshore Terminal Conditions and that the actions of you and your crew will be bound by them.

Signature of Terminal Representative

ACKNOWLEDGEMENT AND ACCEPTANCE BY MASTER

I accept and agree to the above.

Signature of Master

Name of Master

C.6 Safety Letter

FPSO Ichthys Venturer

Date...../...../.....

The Master

MV.....

Dear Captain,

Responsibility for the safe conduct of operations onboard your vessel whilst your vessel is at this Terminal rests with you, as Master of the vessel.

Before operations commence, your full cooperation and understanding is sought of the Terminal safety requirements, which are based on safe practices widely accepted by the global communities.

It is expected that you and your crew will strictly comply with the Terminal safety requirements whilst your vessel is visiting the Terminal. This same expectation applies to all Terminal personnel together with the expectation of full cooperation between all parties in the interest of safe and efficient operations.

Prior to the commencement of operations, and periodically thereafter, the Terminal Representative and, where appropriate, a Responsible Officer, may conduct a routine inspection of your vessel to ensure that the questions in the Terminal safety checklist can be answered in the affirmative.

Where appropriate corrective action is required so as to answer the questions in the Terminal safety checklist in the affirmative, operations will not be commenced, nor should they have commenced, be stopped immediately, until the situation has been satisfactorily rectified.

It is expected that if you and or your crew consider safety is compromised by any Terminal personnel action or equipment, you will communicate this to the Terminal Representative and all operations will cease until the situation has been satisfactorily rectified.

Signed.....

Signed.....

Master

Terminal Representative

MV.....

Date...../...../.....Time.....

C.7 Security Declaration

Name of Vessel:

Port of Registry:

IMO Number:

Name of Terminal:

Last Port Visited:

This Declaration of Security is valid from until, for the following activities (list the activities with relevant details) under the following security levels

Security level(s) for the Vessel:

Security level(s) for the Terminal :

The Terminal and Vessel agree to the following security measures and responsibilities to ensure compliance with the requirements of the International Ships and Ports Security (ISPS) Code.

Activity	The Terminal :	The Vessel:
Ensuring the performance of all security duties		
Monitoring restricted areas to ensure that only authorized personnel have access		
Controlling access to Terminal		
Controlling access to the Vessel		
Monitoring of Terminal, including areas surrounding the Vessel		
Monitoring of the Vessel, including berthing areas and areas surrounding the Vessel		
Handling of cargo		
Delivery of Vessel's stores	N/A	N/A
Handling unaccompanied baggage		
Controlling the embarkation of persons and their effects		

Activity	The Terminal :	The Vessel:
Ensuring that security communication is readily available between the Vessel and Terminal		

The signatories to this agreement certify that security measures and arrangements for both the Terminal and the Vessel during the specified activities meet the provisions of the ISPS Code and will be implemented in accordance with the provisions already stipulated in their approved plan(s) or the specific arrangements agreed to and set out in the attached annex.

Dated at on the

Signed for and on behalf of	
the Offshore Facility:	the Vessel:

(Signature of the Offshore Facility Security Officer) (Signature of Master or Vessel Security Officer)

Name and title of person who signed	
Name:	Name:
Title:	Title

Contact Details

Offshore Facility

Master

Offshore Facility Security Officer

Vessel Security Officer

Company Security Officer

C.8 Approved Smoking Areas

For the duration the Offtake Tanker remains within the Terminal's Petroleum Safety Zone only those smoking areas listed below are to be used onboard.

Vessel Name: _____ Date: _____

Onboard Smoking Locations

1. _____

2. _____

Signed: _____ Signed: _____

Vessel Master

Terminal Representative

C.9 Offtake Tanker Environmental Report

Offtake Tanker:	Date:	Offtake No.:
POB	
Inert Gas Emissions – composition		N2 =% O2 =% CO =% =% =%
Estimated Inert Gas Emissions whilst within PSZ	m3
Main Engine(s) KiloWatts/BHP	KW/BHP
Estimated Main Engine(s) running hours whilst Offtake Tanker within PSZ	hrs
Estimated Fuel Consumption per hour	m3 / Tonne
Fuel Type	
Hull Coating type	
Date Hull Coating last renewed	/...../.....

C.10 Offtake Time Sheet

VESSEL NAME:	Coral Sea	CARGO NUMBER:	
LOADING PORT:	ICHTHYS VENTURER	DISCHARGE PORT:	
MASTER'S NAME:		DATE:	
FPSO TERMINAL ACTIVITY LOG			
Activity	Date/Time Enter data: yyyy-mm-dd tt:tt	Elapsed Time	Metrics
Free Pratique Granted			
E.O.S.P			
NOR Tendered			
Pilot and Surveyor On Board			
Tanker Box Onboard			
Commenced Approach			
Commenced Gauging			
Completed Gauging		00:00	Gauging
First Line		00:00	Harbour Steaming Inbound
All Fast		00:00	Mooring Operations
NOR Accepted			
Offtake Hose Received			
Static Tow Fast			
Commenced Hose Connection			
Complete Hose Connection		00:00	Hose Connection
Complete Ship/Shore Consultation			
Safety Inspection complete			
Butterfly Valve Opened & Locked			
Cargo pump trips tested			
Commenced loading		00:00	Preparations to Load
Commenced Deballasting			
Increased to maximum		00:00	Deballasting Time

rate			
Complete Deballasting			
Reduced loading rate		00:00	Bulk Loading
Complete loading		00:00	Total Loading Time
Commence Gauging			
Butterfly Valve Closed & Locked			
Commenced Hose Disconnection			
Hose Disconnected From Manifold		00:00	Total Hose Connected
Hose Let Go			
Complete Gauging		00:00	Gauging
Lab analysis received by Tanker			
Calculations Complete			
Samples On Board			
Commenced Letting Go			
All Gone and Clear		00:00	Total Berth Time
Static Tow Let Go			
Documents Completed			
Pilot and Surveyor Away		00:00	Harbour Steaming Outbound
RFAOP		00:00	Total Port Time
REMARKS			
DELAYS LOG			
Activity	Start	Finish	Comments

Total Used Laytime:

Remarks:

Verified and Certified by the Following parties:

Place of Issue: FPSO Venturer, Australia

Date of Issue:

.....

.....

[Name in print]
Vessel Master / Agent for Vessel Master

[Name in print]
Signed for and on behalf of Terminal

.....
[Signature]

.....
[Signature]

C.11 Cargo Loading Plan

Offtake Tanker: Date: Offtake No.:

HEEL / ROB

(Show Condensate for each tank)

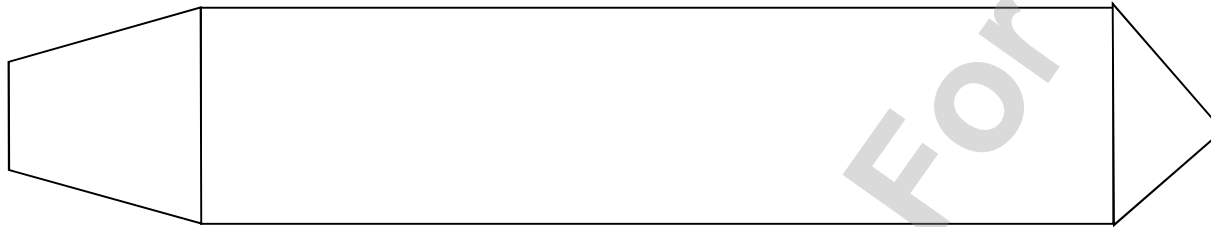

Last Three Cargoes:

1. _____

2. _____

3. _____

Issued For Use

STOWAGE / LOADING PLAN

(Show Condensate for each tank)

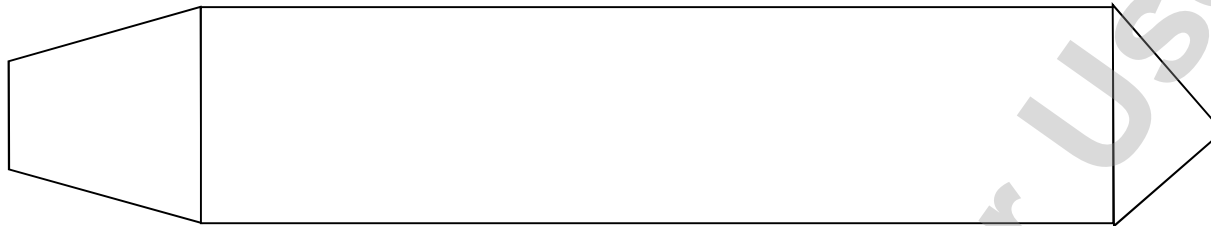

Condensate _____ m3@ 15 0C / 33 0C

Maximum Pumping Rate	
	m3/hour
Maximum Tanker Pumping Pressure allowed	bar / kPa
Initial / Final Pumping Rate	m3/hour
Expected Pumping Pressure	bar / kPa
Ship or Terminal Stop	Ship / Terminal
Line Clearance Volume	m3
Line Clearance Pressure	bar / kPa

COMMENTS:

GENERAL REQUIREMENTS

Communications

Communications between the Offtake Tanker and Terminal will be primarily on VHF radio Ch. 8. Should this VHF radio fail, secondary communications will be UHF radio Ch _____

Each hour (on the hour), the cargo quantity loaded in cubic metres at 15 degrees Celsius and the loading rate in cubic metres at 15 degrees Celsius must be communicated from the Offtake Tanker to the Terminal.

All cargo quantities must be in m³ at 15 degrees Celsius.

In addition at this time, weather forecast information must be communicated between the Terminal and the Offtake Tanker.

The mooring hawser load must be communicated between the FPSO CCR, Pilot Loading Master and Offtake Tanker Cargo Control Room as and when necessary.

C.12 Offtake Tanker / Terminal Safety Checklist

General	Offtake Tanker	Terminal	Code	Remarks
1. Is the Offtake Tanker securely moored?			R	Offtake Tanker crew to inspect mooring regularly
2. Is the Offtake Tanker ready to move under its own power?			PR	
3. Is there an effective deck watch in attendance onboard and adequate supervision on the Terminal and on the Offtake Tanker?			R	Three men on deck at all times – one man forward and one at the manifold. The third man to maintain rounds of the deck area
4. Is the agreed Offtake Tanker/Terminal communication system operative?			AR	Refer to the Cargo Loading Plan
5. Has the emergency signal to be used by the Offtake Tanker and Terminal been explained and understood?			A	Refer to Fire / Emergency Instructions
6. Have the procedures for cargo and ballast handling been agreed?			AR	Refer to the Cargo Loading Plan

General	Offtake Tanker	Terminal	Code	Remarks
7. Are unused cargo and bunker connections properly secured with blank flanges fully bolted?				
8. Are sea and overboard discharge valves, when not in use, closed and visibly secured?				Sea valves sealed and only to be opened under supervision of the Terminal Representative
9. Are all cargo and bunker tank lids closed?				
10. Are hand torches of an approved type?				
11. Are portable UHF/VHF transceivers of an approved type?				
12. Are the Offtake Tanker's main transmitter aerials earthed and radars switched off?				
13. Are electric cables to portable electrical equipment disconnected from power?				
14. Are all external doors and ports in the accommodation closed?			R	Identify access door

General	Offtake Tanker	Terminal	Code	Remarks
15. Are air conditioning intakes, which may permit the entry of cargo vapours closed?				All doors, portholes and openings from the outer deck to accommodation or machinery spaces (other than the pumproom) shall be kept closed except for entry/exit purposes. All ventilators through which gas can enter shall be closed and mechanical ventilation shall be stopped if gas is being drawn into the system. Window type air conditioning units must not be used. Normal air conditioning or mechanical ventilation must be used in a mode that maintains a positive pressure sufficient to prevent the ingress of any hydrocarbon gas through doors, ports or hatches which are not gas tight or monitored by gas detectors.
16. Are the requirements for use of galley equipment and other cooking appliances being observed?				
17. Are smoking regulations being observed?			R	
18. Are naked light regulations being observed?				
19. Is there provision for an emergency escape?				
20. Are adequate insulating means in place in the Offtake Tanker / Terminal connection?				
21. Are Offtake Tanker fire control plans located externally?				

Additional	Offtake Tanker	Terminal	Code	Remarks
22. Is the agreed tank venting system being used?			AR	
23. Has the operation of the P/V valves and/or high velocity vents been verified using the check lift facility, where fitted?				
24. Have measures been taken to ensure sufficient pumphouse ventilation?			R	
25. Have the requirements for closed loading been agreed?			PR	
26. Has the Offtake Export Loading Hose butterfly valve been opened and locked open with securing bolt(s)?			R	Time
27. Is the Inert Gas System fully operational and in good working order?				
28. Are deck seals in good working order?			R	

Additional	Offtake Tanker	Terminal	Code	Remarks
29. Are liquid levels in P/V breakers correct?			R	
30. Have the fixed and portable oxygen analysers been calibrated and are they working properly?			R	
31. Are fixed IG pressure and oxygen content recorders working?			R	
32. Are all cargo tank atmospheres at positive pressure with an oxygen content of 8% or less by volume?			PR	Tanks tested and readings recorded
33. Are all individual tank IG valves (if fitted) correctly set and locked?			R	
34. Are all persons in charge of cargo operations aware that in the case of Inert Gas Plant failure, cargo operations should cease and the Terminal be advised?				

The presence of the letters A, P or R in the column "Code" indicates the following:

A – any procedures and agreements should be in writing in the remarks column of this Checklist or alternatively attached to this Checklist together with the signature of both parties.

P – in the case of a negative answer, the operation shall not be undertaken and the Offtake Tanker unmoored from the Terminal.

R – indicates items to be re-checked at intervals not exceeding "6" hours

DECLARATION

We the undersigned have checked, where appropriate jointly, the items on this checklist and have satisfied ourselves that the entries we have made are correct to the best of our knowledge.

We the undersigned have also made arrangements to carry out repetitive checks necessary and agreed that those items together with items with the letter 'R' in the column 'Code' shall be re-checked by ourselves at intervals not exceeding _____ hours.

Signed.....

Signed.....

Master

Terminal Representative

SS/MV.....

Date...../...../.....Time.....

Issued For Use

Record of repetitive checks of ship shore safety checks:					
Date:					
Time:					
Initials for Vessel:					
Initials for Shore:					

b.

Record of repetitive checks of Ship / Shore Safety Checks:					
Date:					
Time:					
Initials for Vessel:					
Initials for Shore:					

Record of repetitive checks of Ship / Shore Safety Checks:					
Date:					
Time:					
Initials for Vessel:					
Initials for Shore:					

C.13 Notes Of Protest

Date...../...../.....

Cargo/Offtake No.:.....

Offtake Tanker.....

Master.....

The following incident and/or deficiency noted below has occurred and is being brought to your attention.

Where applicable you and your vessel will be held responsible for claims or indemnities resulting from the above.

.....
Terminal Representative

Received by:.....

Offtake Tanker Master

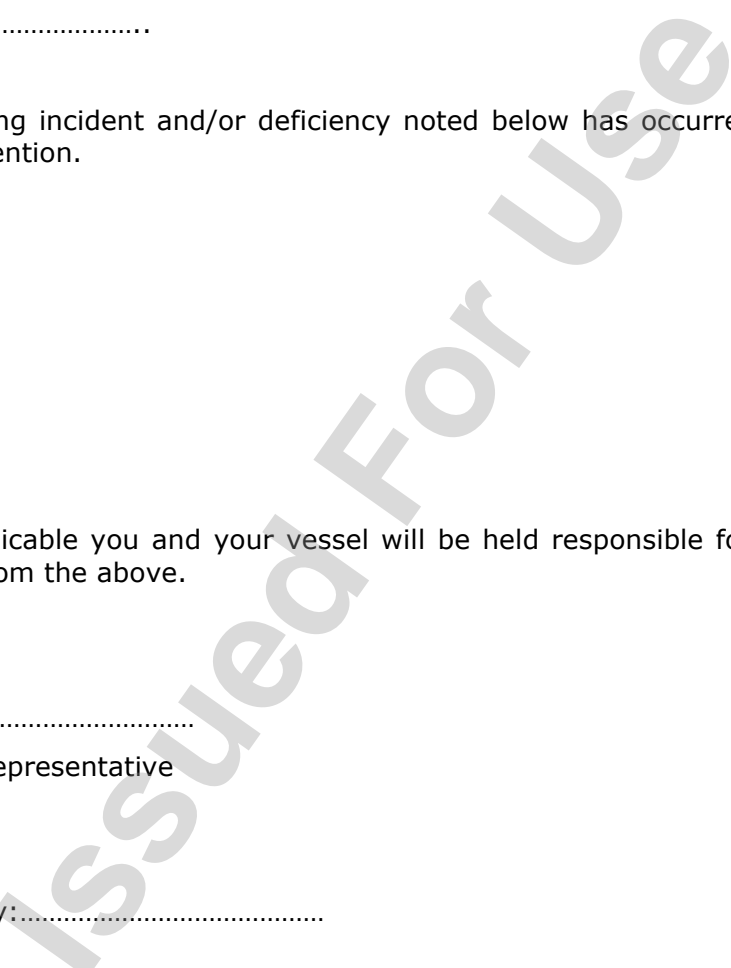

C.14 Weather Parameters

Status	Observed Wave Height (m)	Wind (Kts) (10min Average)	Visibility (nm)
Open (No Limitations)	<2.5	<25	> 2
Restricted ¹	>2.5 and < 3.0	>25 and <35	< 2
Closed ²	> 3.0	>35	-

Note 1: No Offtake Tanker is permitted to moor. An Offtake tanker already moored may continue offtake operations subject to pilot advice and hawser load tension.

Note 2: No Offtake Tanker is permitted to moor. An Offtake Tanker already moored will be required to disconnect and depart if safe to do so.

Adverse Weather and Thunder Storms

In making the determinations regarding adverse weather and risk of lightning strike the Operators Adverse Weather Procedure (X060-AH-PRC-60017) is to be followed.

When Thunder Storms and lightning is in the immediate vicinity of the FPSO and approaching the facility, the FPSO OIM, Pilot and the Offtake Tanker Master will consult and determine if/when offtake operations will be suspended.

Offtake tankers should consider reducing venting through the mast riser and in some cases close the mast riser valve, during thunderstorm activity.

Extreme Weather

Offshore Cyclone Management Plan (X060-AH-PLN-60001)

The decision to depart the berth due to a forecasted deterioration in weather conditions must be made in sufficient time to allow for safe departure from the Terminal.

Issued For

C.15 Terminal Feedback on Vessel

Terminal Feedback on Vessel		
Vessel Name	LR/IMO No.	Flag
<input type="checkbox"/> Check here if Note of Protest Issued.		
Comment below:		
<input type="checkbox"/> Check here if any Pollution Violation. Attach copy of report.		

Inspection Date:		Agent:	
-------------------------	--	---------------	--

Terminal:	Berth:	Arrival Date:	Departure Date
Darwin, Bladin Point <input type="checkbox"/> Ichthys Field <input type="checkbox"/>	Jetty #1 (LPG / Condensate) <input type="checkbox"/> Jetty #2 (LNG) <input type="checkbox"/> FPSO (Condensate) <input type="checkbox"/>		

Cargo	Transfer Operations	
LNG <input type="checkbox"/> LPG <input type="checkbox"/> Condensate <input type="checkbox"/>	Loading <input type="checkbox"/> Discharging <input type="checkbox"/>	
Loading/ Discharging Rates: (m3/h)		
Average:	Actual:	Planned:
Nationality:	Officers:	
	Crew:	

Ratings

S = Satisfactory; N = Needs Improvement; U = Unsatisfactory; X = Not Observed.
Please explain all "Yes", "U", and "N" ratings in the comment section.

Item:	Rating:	Comment:
Pre-arrival information exchanged and satisfactory?	<input type="checkbox"/> S <input type="checkbox"/> N <input type="checkbox"/> U <input type="checkbox"/> X	
Pilotage & berthing satisfactory? Vessel equipment & manoeuvrability?	<input type="checkbox"/> S <input type="checkbox"/> N <input type="checkbox"/> U <input type="checkbox"/> X	
Vessel compliant with all terminal regulations?	<input type="checkbox"/> S <input type="checkbox"/> N <input type="checkbox"/> U <input type="checkbox"/> X	
Gangway and/or access to the vessel satisfactory?	<input type="checkbox"/> S <input type="checkbox"/> N <input type="checkbox"/> U <input type="checkbox"/> X	
Mooring arrangement per computer-based mooring analysis?	<input type="checkbox"/> S <input type="checkbox"/> N <input type="checkbox"/> U <input type="checkbox"/> X	
Pre-cargo Transfer Information Exchange and Safety Check List performed?	<input type="checkbox"/> S <input type="checkbox"/> N <input type="checkbox"/> U <input type="checkbox"/> X	
Post cargo closeout meeting satisfactory? Open comments?	<input type="checkbox"/> S <input type="checkbox"/> N <input type="checkbox"/> U <input type="checkbox"/> X	
Readiness of safety, firefighting & emergency response equipment?	<input type="checkbox"/> S <input type="checkbox"/> N <input type="checkbox"/> U <input type="checkbox"/> X	
Effective cargo watch to monitor ship's movement while alongside. Lines well attended by ships staff. No movement or alarms?	<input type="checkbox"/> S <input type="checkbox"/> N <input type="checkbox"/> U <input type="checkbox"/> X	
Operational communications (Alongside) satisfactory? Ship/Shore link communication link working satisfactory?	<input type="checkbox"/> S <input type="checkbox"/> N <input type="checkbox"/> U <input type="checkbox"/> X	
Manifold area suitable with adequate lighting and water curtain system operational?	<input type="checkbox"/> S <input type="checkbox"/> N <input type="checkbox"/> U <input type="checkbox"/> X	
Effective cooling down of manifold and lines prior loading or discharge?	<input type="checkbox"/> S <input type="checkbox"/> N <input type="checkbox"/> U <input type="checkbox"/> X	

Item:	Rating:	Comment:
Condition of cargo containment system? Arrived ready for cargo operations? Condition of ships lines pre/post loading?	<input type="checkbox"/> S <input type="checkbox"/> N <input type="checkbox"/> U <input type="checkbox"/> X	
Nitrogen system performance?	<input type="checkbox"/> S <input type="checkbox"/> N <input type="checkbox"/> U <input type="checkbox"/> X	
Cold/Warm ESD testing satisfactory? ESD timing correct?	<input type="checkbox"/> S <input type="checkbox"/> N <input type="checkbox"/> U <input type="checkbox"/> X	
Custody Transfer System properly initiated and closed?	<input type="checkbox"/> S <input type="checkbox"/> N <input type="checkbox"/> U <input type="checkbox"/> X	
Ballast discharge monitored?	<input type="checkbox"/> S <input type="checkbox"/> N <input type="checkbox"/> U <input type="checkbox"/> X	
Deck lighting adequate for safe night-time operations? Ability to reduce light emissions for environmentally sensitive areas?	<input type="checkbox"/> S <input type="checkbox"/> N <input type="checkbox"/> U <input type="checkbox"/> X	
Cargo pumps and cargo compressors in good order?	<input type="checkbox"/> S <input type="checkbox"/> N <input type="checkbox"/> U <input type="checkbox"/> X	
Ramp up/Ramp down rates and pressures per agreement with terminal?	<input type="checkbox"/> S <input type="checkbox"/> N <input type="checkbox"/> U <input type="checkbox"/> X	
Officers and crew conduct & professional knowledge?	<input type="checkbox"/> S <input type="checkbox"/> N <input type="checkbox"/> U <input type="checkbox"/> X	
Safety/Environmental practices and compliance?	<input type="checkbox"/> S <input type="checkbox"/> N <input type="checkbox"/> U <input type="checkbox"/> X	
General vessel appearance, including accommodation?	<input type="checkbox"/> S <input type="checkbox"/> N <input type="checkbox"/> U <input type="checkbox"/> X	
Do the officers and crew involved in cargo operations appear adequately rested?	<input type="checkbox"/> S <input type="checkbox"/> N <input type="checkbox"/> U <input type="checkbox"/> X	
Comprehensive cargo & ballast plans in place and being followed?	<input type="checkbox"/> S <input type="checkbox"/> N <input type="checkbox"/> U <input type="checkbox"/> X	
Strainers used and mesh size? Condition post cargo operations?	<input type="checkbox"/> S <input type="checkbox"/> N	

Item:	Rating:	Comment:
	<input type="checkbox"/> U <input type="checkbox"/> X	
Gas-up and/or cool down. Time to change over & time required each step?	<input type="checkbox"/> S <input type="checkbox"/> N <input type="checkbox"/> U <input type="checkbox"/> X	
Vapour management performance?	<input type="checkbox"/> S <input type="checkbox"/> N <input type="checkbox"/> U <input type="checkbox"/> X	
Gas detection system satisfactory? Specify any hydrocarbon readings.	<input type="checkbox"/> S <input type="checkbox"/> N <input type="checkbox"/> U <input type="checkbox"/> X	
Proper transfer arm & manifold draining, purging & disconnection per SIGTTO January 2012 guidance paper?	<input type="checkbox"/> S <input type="checkbox"/> N <input type="checkbox"/> U <input type="checkbox"/> X	
Other	<input type="checkbox"/> S <input type="checkbox"/> N <input type="checkbox"/> U <input type="checkbox"/> X	
Pilot Boarding Arrangements?	<input type="checkbox"/> S <input type="checkbox"/> N <input type="checkbox"/> U <input type="checkbox"/> X	
Vessel acceptable at this terminal	<input type="checkbox"/> Yes <input type="checkbox"/> No	

Additional Comments	
----------------------------	--

Inspector:	Title:	Signature:
	Loading Master	

Please return this form to the INPEX Lifting Coordinator.

C.16 Vessel Feedback on Terminal

Vessel Feedback on Terminal Form	
Vessel Name	Flag
Terminal	Darwin, Bladin Point <input type="checkbox"/> Ichthys Field <input type="checkbox"/>
Cargo	LNG <input type="checkbox"/> LPG <input type="checkbox"/> Condensate <input type="checkbox"/>
Lifting No.	LR / IMO No.
Pilot	Load Master

Ratings

S = Satisfactory; N = Needs Improvement; U = Unsatisfactory; X = Not Observed.
Please explain all "Yes", "U", and "N" ratings in the comment section.

Item:	Rating:	Comment:
Pre arrival communication and information	<input type="checkbox"/> S <input type="checkbox"/> N <input type="checkbox"/> U <input type="checkbox"/> X	
Pilotage and berthing	<input type="checkbox"/> S <input type="checkbox"/> N <input type="checkbox"/> U <input type="checkbox"/> X	
Mooring operations	<input type="checkbox"/> S <input type="checkbox"/> N <input type="checkbox"/> U <input type="checkbox"/> X	
Gangway and/or access to vessel	<input type="checkbox"/> S <input type="checkbox"/> N <input type="checkbox"/> U <input type="checkbox"/> X	
Pre loading meeting	<input type="checkbox"/> S <input type="checkbox"/> N <input type="checkbox"/> U <input type="checkbox"/> X	
Loading operations	<input type="checkbox"/> S <input type="checkbox"/> N <input type="checkbox"/> U <input type="checkbox"/> X	
Post loading meeting	<input type="checkbox"/> S <input type="checkbox"/> N <input type="checkbox"/> U <input type="checkbox"/> X	
Terminal equipment	<input type="checkbox"/> S <input type="checkbox"/> N <input type="checkbox"/> U <input type="checkbox"/> X	

	Item:	Rating:	Comment:
	Operational communications	<input type="checkbox"/> S <input type="checkbox"/> N <input type="checkbox"/> U <input type="checkbox"/> X	
	Did the vessel have any safety concerns during the visit?	<input type="checkbox"/> Yes <input type="checkbox"/> No	

Additional Comments	
----------------------------	--

	Master	Pilot	Load Master
Name			
E-Mail			
Signature			

Please return this form to the Loading Master

Mooring Hawser Assembly Arrangement

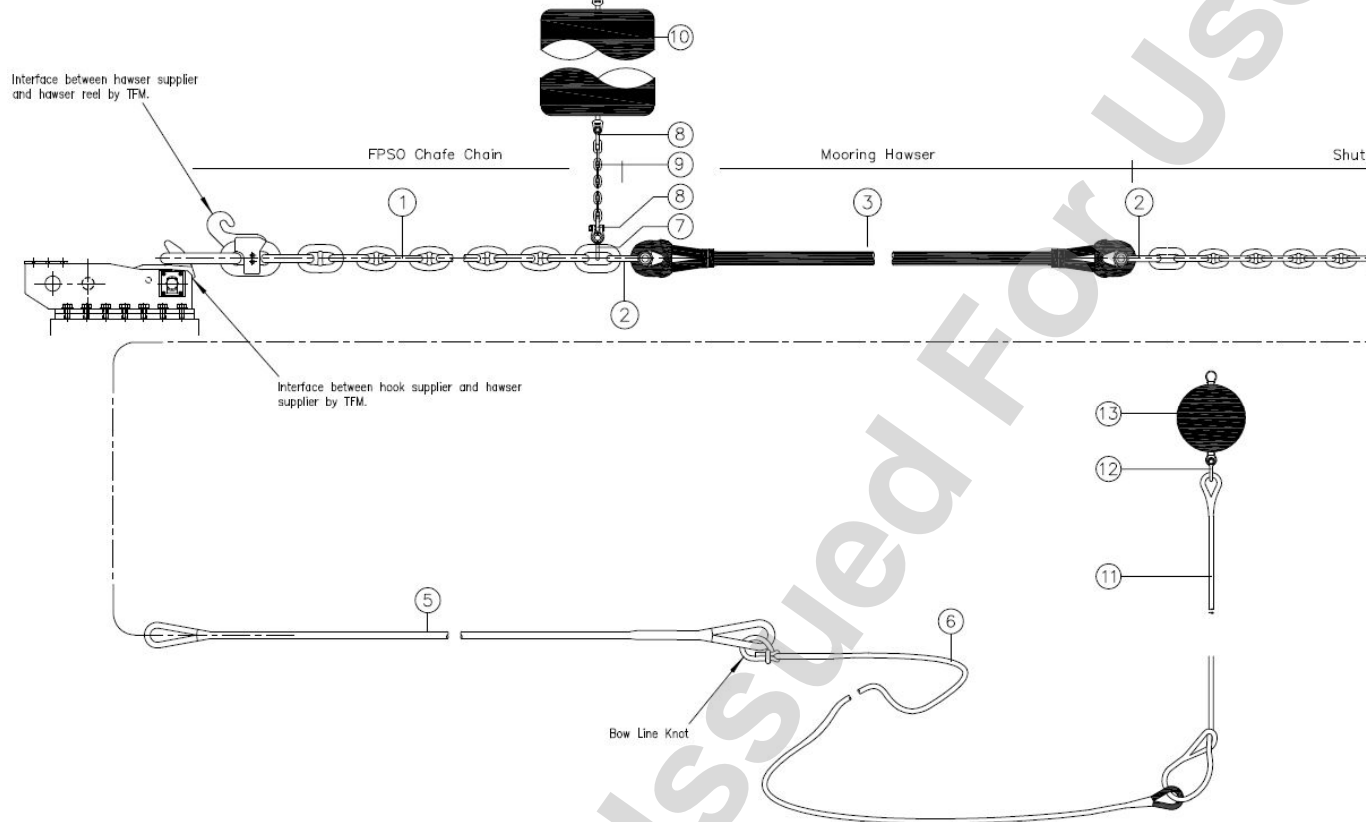

10	1	SHUTTLE TANKER CHAIN SUPPORT BUOY Cylindrical chain support buoy. Manufactured from a core of thermolaminated polyethylene foam (Density: 30-35 kg/cu.m), encapsulated in a tough yet resilient polyurethane elastomer skin. Orange colour. Supplied complete with central hot dipped galvanised steelwork fitted with a swivel eye (WLL 10t) each end. Diameter of buoy: 1380 mm Length of buoy body: 2000mm Overall length of buoy: 2620mm Nett Buoyancy: 2500 kgs
9	1	SUPPORT BUOY CHAIN 26mm Dia. Studlink chain assembly. Manufactured from grade 2 material. Comprising all common links c/w Enlarged & End link each end. Overall length 5 metres.
8	2	BUOY SHACKLE 1 3/8" Galvanised Bow safety pin type shackle. Working Load Limit: 13.5 t
7	1	BUOY SHACKLE 2 1/2" Galvanised Dee safety pin type shackle. Working Load Limit: 55 t
6	1	PICK-UP ROPE 150 Metre finished length pick-up rope. 3" Circ. Lankhorst TIPTO TWELVE Brand 12-strand roundline rope. High visibility yellow colour. Specific gravity - 0.93 (floating). Supplied complete with a 2 mtr PTC protected soft eye spliced each end. Minimum Break Strength of Rope: 103 kN
5	1	MESSENGER LINE 150 Metre finished length messenger line. 10" Circ. Lankhorst TIPTO EIGHT Brand 8-strand multiplait rope. High visibility yellow colour. Specific gravity - 0.93 (floating). Supplied complete with a 2 mtr PTC protected soft eye spliced each end. Minimum Break Strength of Rope: 992 kN
4	1	SHUTTLE TANKER CHAFE CHAIN Chafe Chain 'B' as per OCIMF Guidelines, 4th edition - 2007. Manufactured from 76mm Dia. Studlink chain, grade R3 material in accordance with IAS W22. WLL: 200 t ; PL: 330 t ; MBL: 498 t. Comprising of:- 1 x Special end link (95mm Dia., 370 x 130mm i/s) 1 x Enlarged link 24 x Common links 1 x OCIMF Rating plate 1 x 42t WLL Flush pin pick-up shackle Total Length approx 8m
3	1	MOORING HAWSER 80 Metre finished length single leg type mooring hawser as measured under OCIMF 2000 Guidelines. 19" Circ. Lankhorst GAMA 98 Brand circular braided 100% nylon rope. Supplied with a galvanized cast steel type thimble (Size 19/21) spliced each end. Thimbles polyurethane encapsulated. New Dry Break Strength of Rope: 6322 kN New Wet Break Strength of Rope: 6082 kN
2	2	HAWSER SHACKLE Heavy duty hawser shackle, painted finish, complete with double nuts and stainless steel cotter pins. Size 21. Size: 115 x 125 x 280 x 500 Leng. Palm 238mm Working Load Limit: 200 t Proof Load: 330 t Working Load Limit: 498 t Coating shall be to 5900-AL-SPC-10001. Material: Stainless Steel GR.316L
1	1	FPSO CHAFE CHAIN ASSEMBLY 76mm dia., Studlink chain assembly. Manufactured from grade R3 material in accordance with IAS W22. WLL: 200 t ; PL: 330 t ; MBL: 498 t Comprising of:- 1 x Hook Link (115mm dia., 978mm x 280mm i/s). 1 x Step Down link c/w Hook adaptor. 1 x Special End Link 1 x Enlarged Link 21 x Common Links 1 x Enlarged Link 1 x Special End Link (95mm Dia., 370 x 130mm i/s). Total Length approx 8.9m

Offtake Hose

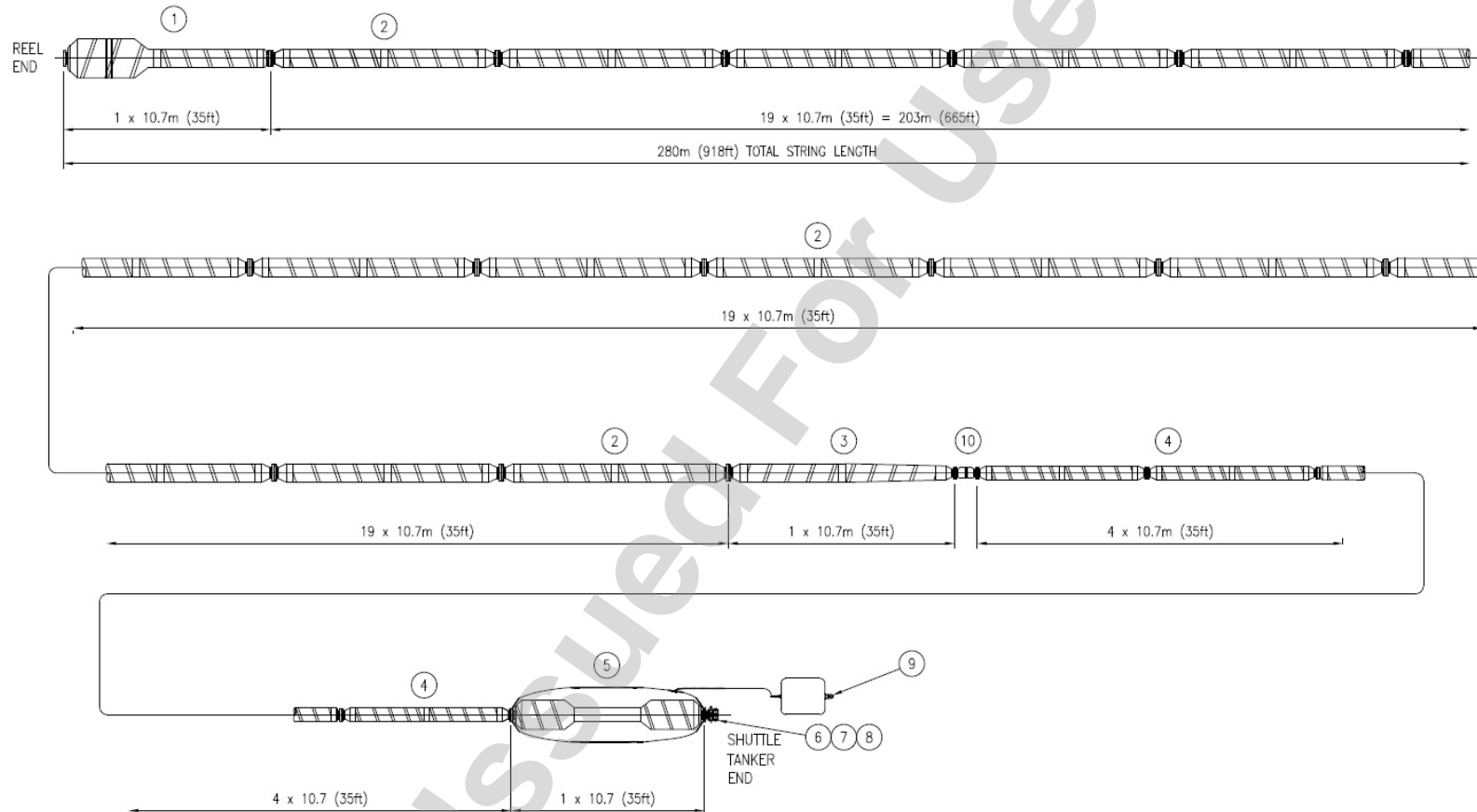

NOTES:

1 - HOSE MANUFACTURED IN ACCORDANCE WITH OIL COMPANIES INTERNATIONAL MARINE FORUM (OCIMF) GUIDE TO PURCHASING, MANUFACTURING AND TESTING OF LOADING AND DISCHARGE HOSES FOR OFFSHORE MOORINGS 4th. EDITION 1991.
(INCLUDING MANUFACTURERS FULL ACCREDITATION TO ISO 9001 AS REQUIRED BY OCIMF 1991).

2 - HOSE FLANGE CONNECTIONS TO BE ANSI B16.3 CLASS 300.

10	1	16" MARINE BREAKAWAY COUPLING	
9	1	16" SWL TONNE PICK UP BODY AND FITTINGS	
8	1	16" CAMLOCK COUPLING	
7	1	16" BLIND FLANGE	
6	1	16" BUTTERFLY VALVE	
5	1	16" x 10.7m FLOATING BARRELL TANNER RAIL HOSE	
4	4	16" x 10.7m FLOATING TAIL HOSE	
3	1	20" - 16" x 10.7m FLOATING TAPER MANLINE HOSE	
2	19	20" x 10.7m FLOATING MANLINE HOSE	
1	1	20" x 10.7m FLOATING REELING HOSE - REEL END	

C.17 Inpex Master Pilot Exchange Ichthys Field

Vessel Name		Date	
From		Cargo Number	
To		Arrival Draft (Actual)	F: m A: m
Pilot		Departure Draft	F: m A: m

Tugs / Assist Vessels	Draught	SWL – V/L Bitts	Tug Positions
1			
2			
Note: Tugs will use tug line. When letting go tug/s, lines MUST be lowered, NOT dropped.			

Vessel Checks			
Engines Tested Ahead / Astern	Y / N	Passage Plan Agreed	
Any Engine Issues	Y / N	Pilot Card Viewed	
Main Engine(s) Kilowatts/BHP		Location of Main Engine(s) control whilst loading	Bridge/CCR
Main Engine(s) response (from ahead to astern)	Good / Poor	Navigation equipment in good working order	
Number of Main Engine(s) consecutive starts		Gyro Compass & Repeaters Checked	Y / N
Can Main Engine(s) be run continuously for periods of up to 24 hours	Y / N	Gyro Error	° H/L
Propeller	LH / RH	Echo Sounder	Y / N
Steering Tested (2 steering motors on)	Y / N	Whistle Located & Tested	Y / N
Bow Thruster Tested & Operational	Y / N	GPS (set to WGS84)	Y / N
Radar(s) Operational and Setup	Y / N	AIS (set to 'Underway' mode throughout) correctly and transmitting	Y / N
ECDIS or Plotter	Y / N	VHF Radios Tested	Y / N
Is vessel in ballast	Y / N	Any Known Defects – (record in Notes)	Y / N
Cargo on board	M3 / MT	Arrival Displacement	MT

Pilotage Information Checks			
Working VHF Channel		Backup VHF Channel	Port VHF Channel
Communications failure discussed - Sound 1 Long Blast – Change to VHF-xx			Y / N
Abort Points / Contingencies discussed – (record on the Plan / Notes)			Y / N
Navigation Hazards / Safety Alerts and SIMOPS discussed – (record on the Plan / Notes)			Y / N
All Anchors Fully Secured			
Forecastle winch power			
Is the forecastle winch drum clear			

Forecastle chain stopper certificate(s) sighted and valid	
Crew standby forward – winch drum & chain stopper prepared - mooring requirements explained	Y / N
Engineer(s) standing by main engine control stations throughout Pilotage	Y / N
Pilot's PPU set up & Functioning	Y / N
BRM Principles discussed, agreed to and implemented – (Bridge Team / Pilot's Expectations)	Y / N

Assist Tug Checks				
Equipment & Machinery Operational / Radio Communications Verified / PPU Display Operational				
Tug (1)	Y / N	Tug (2)	Y / N	

Notes	Record of Times	
	Arrival Departure Transit	
	Pilot Onboard	
	Commence Berthing / Unberthing	
	Hawser All Fast / Clear	
	All Fast	
	Handover Conduct	
	Pilot Away	

Time Pilot Takes Conduct		*By signing this document, you are agreeing that the Pilot has Conduct of the vessel	
Name of Pilot		Name of Master	
Signature		Signature*	

Berthing & Unberthing Precautions	
<p>Tides / Currents: Strong currents occur in the area. The direction of tidal flow may not follow predictions. The Terminal may rotate one hundred and eighty (180) degrees due to tidal changes and the Offtake Tanker's main engine(s) may be run astern throughout the rotation.</p> <p>Main Engine(s): 1. The main engine(s) must be capable of starting immediately from the designated engine control room position. 2. The main engine(s) must be capable of being run continuously for periods of up to twelve (12) hours. 3. A responsible and qualified engineer must standby the main engine(s) local manoeuvring station throughout the mooring and unmooring</p>	<p>Hawser: Ensure Starboard Chain Stopper is greased & operating correctly Move messenger onto empty – prepared winch storage drum as soon as it is heaved onboard through the forward or Starboard fairlead Weight on messenger & hawser ONLY as directed by the Assistant Mooring Master. When releasing the Hawser – release the Chain Stopper & slack ONLY as directed by the Assistant Mooring Master</p> <p>Hose: Terminal provided 3m Stinger to be attached to the Ship Crane Hook. Wait until the OSV has connected the hose and is clear of the lifting area before heaving up loading hose.</p>

<p>operation to act as backup to any automation, in addition to the normal engine room standby manning level.</p> <p>Tug: The OSVs will act as a "tug" at this Terminal Name/Call Sign: VHF Working Channel: OSV bollard pull = 100 Tonnes The OSV's line shall only be made fast to the Offtake Tanker through a closed fairlead secured to a bollard of SWL _____ Tonnes minimum, which are marked with the SWL "Weighted" heaving lines shall not be used for connection and disconnection of the OSV's line On disconnection of the OSV's line, the line shall be lowered back to the OSV under control at all times unless instructed otherwise by OSV Master/Pilot. At this time, the tanker's main engine will not be operated and until the static tow line has been retrieved and the OSV clear.</p>	<p>Use ONLY the securing points indicated by the Assistant Mooring Master for Hose Chains All Hose-End Camlocks to be fully engaged when securing the Hose to the Ship's Manifold</p>
---	---

Predicted Wind		Actual Wind	
----------------	--	-------------	--

Predicted Current		Sea / Swell	
-------------------	--	-------------	--

FPSO Approach and Mooring Process:

Prior to commencing the approach phase, the Pilot and Surveyor will board the Tanker at a location advised by the Terminal. Once onboard, the Pilot will commence the pre-berthing briefing with the Offtake Tanker Master, whilst the Surveyor supervises the transfer of the tanker box from the OSV and the setting up of equipment at the starboard manifold, poop and forecastle decks.

The Pilot will confirm that the Offtake Tanker and OSV are ready in all respects and request permission from the FPSO OIM prior to commencing the approach toward the Facility.

The approach will be in accordance with the agreed Passage Plan, utilising the Berthing Aid System to verify Offtake Tanker's track and speed over the ground.

The OSV will receive and deploy the mooring hawser system from the FPSO in a direction astern of the Facility and await the approach of the Offtake Tanker.

The Terminal Surveyor / Assistant Mooring Master will supervise mooring operations on the forecastle and prepare to receive the mooring system pick-up line from the starboard bow of the Offtake Tanker. The Surveyor will convey updates of the approach and mooring operation to the Pilot.

At an appropriate distance, the OSV will approach the Tanker's starboard bow, connect the mooring hawser pick-up line to the Tanker's messenger rope and transfer to the Tanker. The OSV will then take up station under the direction of the Pilot.

The mooring hawser assembly will be lead directly onto the Offtake Tanker's forecastle starboard winch drum and heaved in as requested. The mooring hawser chain must be secured in the Offtake Tanker's chain stopper using, as a minimum, the third (3rd) link from the free end. Once confirmed secured the Offtake Tanker's main engine(s) will be run dead slow astern to confirm the mooring integrity.

Throughout the mooring procedure the relative position of the Terminal and Offtake Tanker will be continuously checked by the Terminal and the Surveyor located on the Offtake Tanker forecastle.

The OSV will then transfer the Offtake Export Loading Hose to the Offtake Tanker's starboard side manifold.

Once transferred, the OSV will establish a stern static tow of the Offtake Tanker.

When the static tow is established, the Offtake Tanker's main engine(s) may be stopped, but remain available for immediate use.

Unmooring Process:

The unmooring operation will commence when the Offtake Tanker Master, Pilot, OSV Master and Terminal personnel agree.

At the Pilot's instruction, the OSV will shorten up the static tow line.

The Offtake Export Loading Hose will be released from the Offtake Tanker and reeled in by the Facility prior to the unmooring operation.

Once weight is off the mooring hawser, the mooring hawser will be released from the Offtake Tanker chain stopper and "paid" out in a controlled manner. The Offtake Tanker can commence moving astern and away from the FPSO, at slow speed.

The mooring hawser assembly will be recovered to the Terminal.

The Pilot will manoeuvre the Offtake Tanker to a position well clear of the Terminal and stop in preparation to release the OSV. On the Pilot's instruction, the OSV will recover the tow line until it is in close proximity of the Offtake Tanker's stern. Once all weight is off the static tow line, the Offtake Tanker's crew, under supervision of the Surveyor, will pass the free end of the tow line down to the OSV in a controlled manner.

Note: at this time, the Offtake Tanker's main engine will NOT be engaged.

The OSV will then proceed to the Terminal to collect retained samples for the Offtake Tanker.

The Offtake Tanker's hose handling crane will be readied and the OSV will deliver the Lifter's final retention sample and retrieve the Tanker Box (hose/mooring equipment) and disembark Terminal personnel.

Issued for use

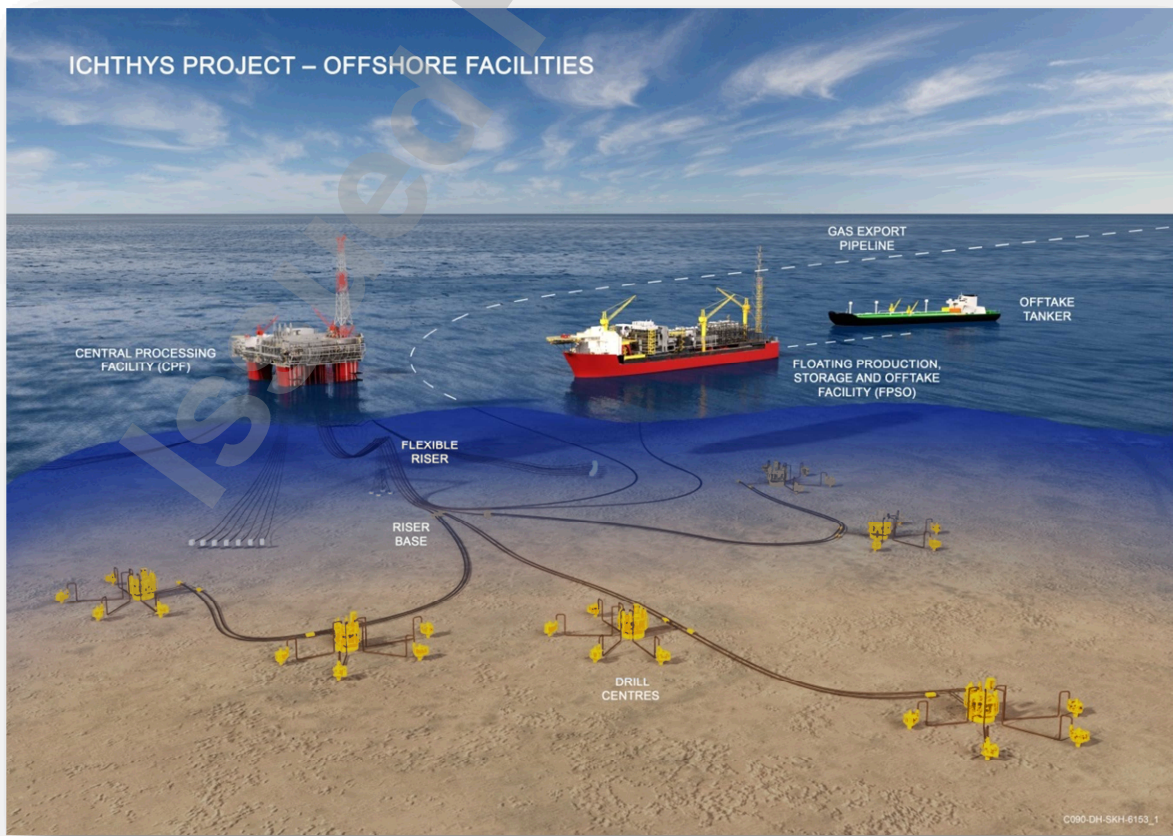
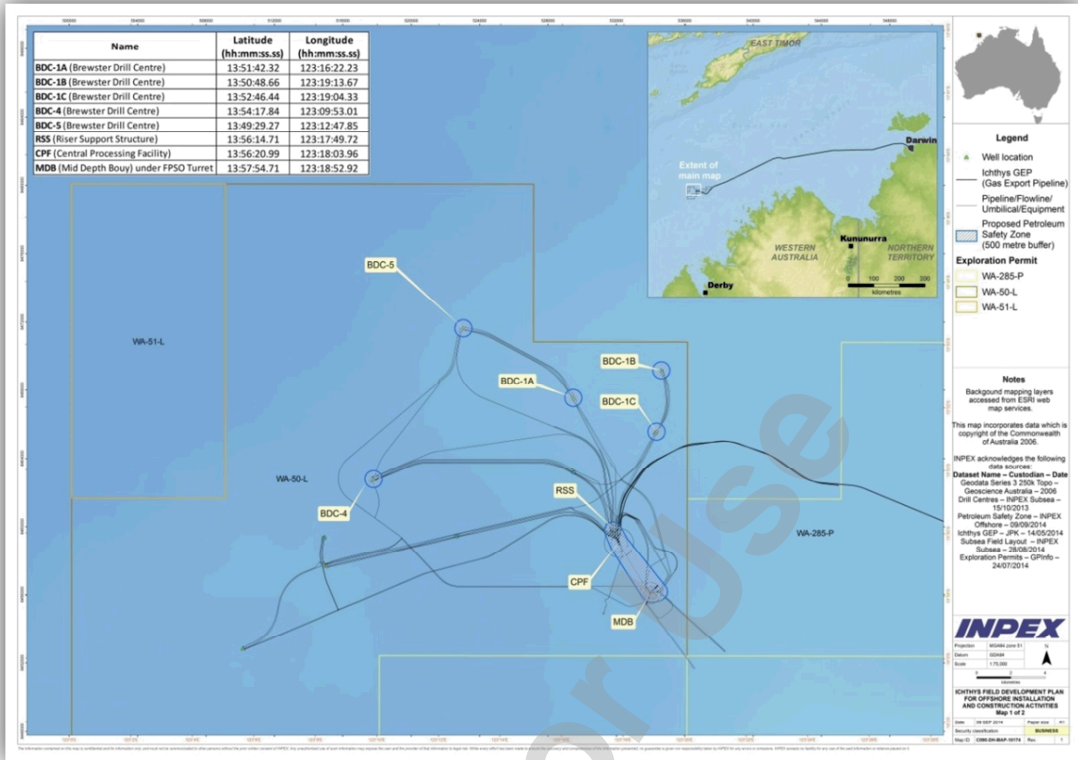



Offtake Tanker No Go Zone

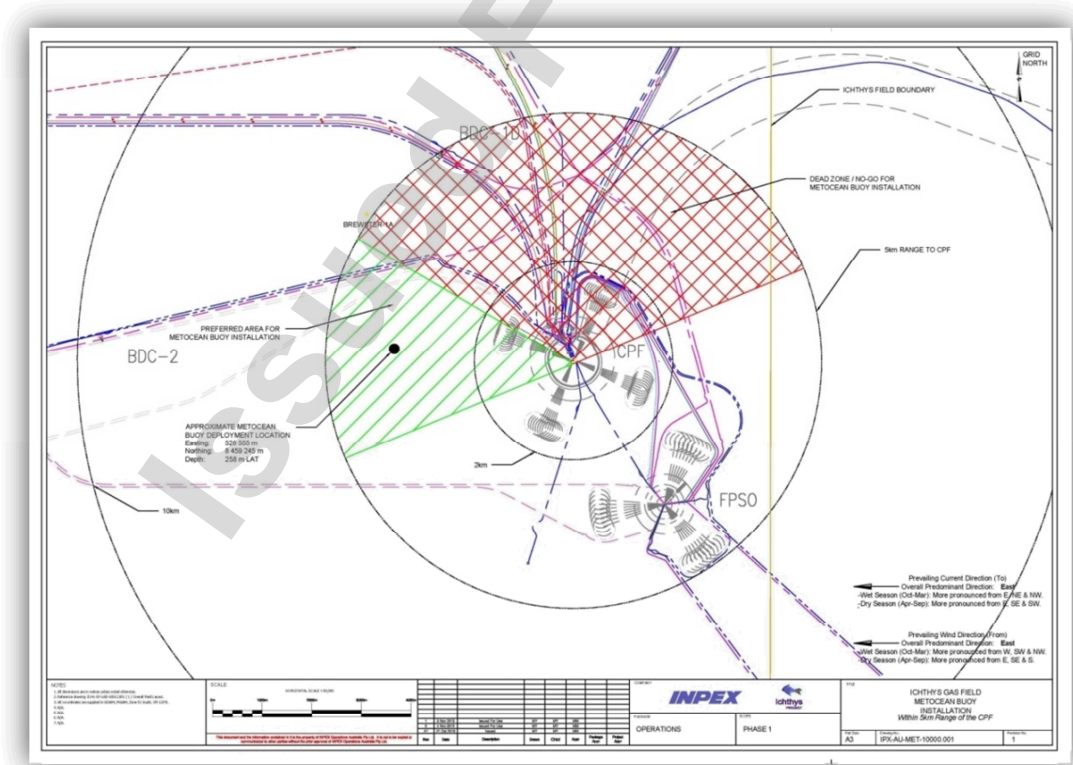

Met-Ocean Buoy Location

C.18 Ichthys Venturer Terminal - Pilotage Passage Plan

AT POSITION 1

Heaving line passed to Support Vessel from tanker starboard shoulder. Support vessel crew will heave ships messenger to deck and secure to Hawser messenger

ON APPROACH

Assistant Mooring Master on forecastle to relay bearing and distance to Support Vessel and to FPSO stern. After pick-up line is onboard, relay bearing and distance to chafe chain

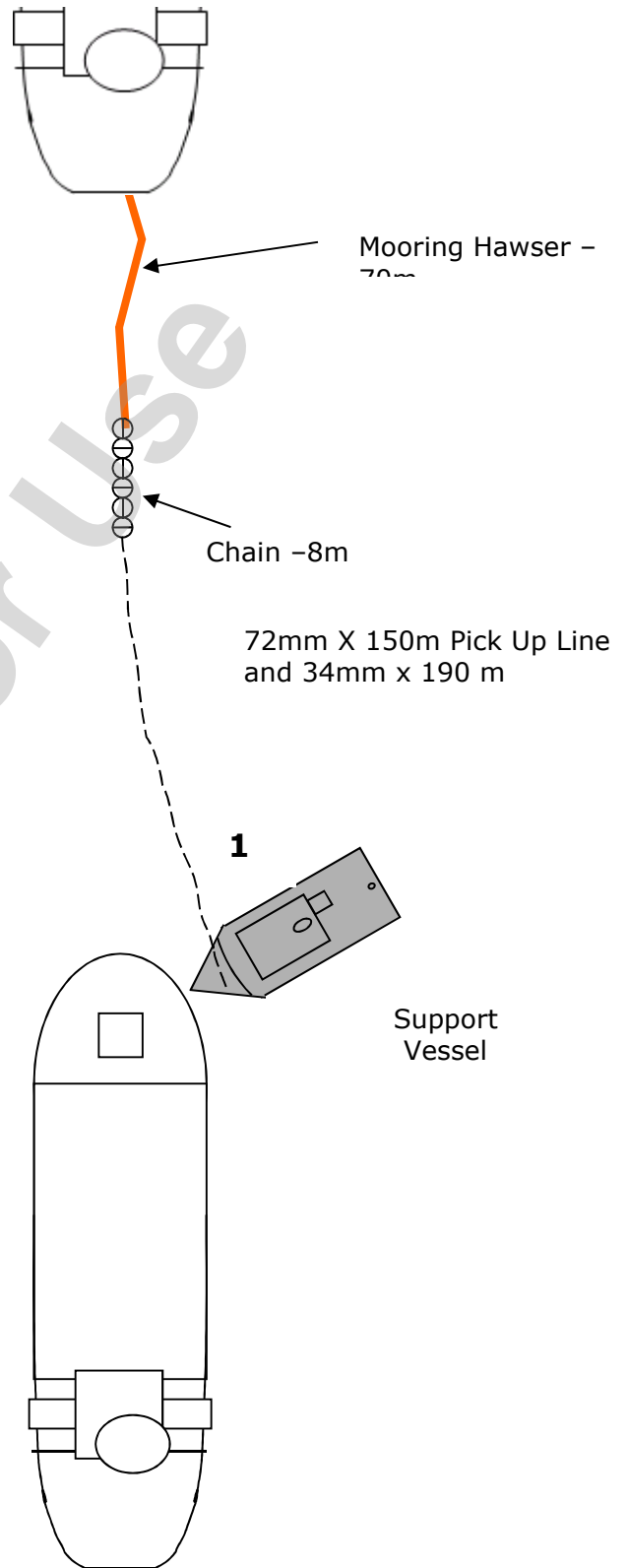

Pilot	
TARGET SPEED	
@ 0.5NM	0.5 - 1 knot
@ Pick up line	0.5 knot
3 Chain Links Minimum In Stopper	
Anchors Secured	<input type="checkbox"/>
Equipment Fully Operational	<input type="checkbox"/>
Tides	
HW _____ M@ _____	_____ hrs
LW _____ M@ _____	_____ hrs

Master:

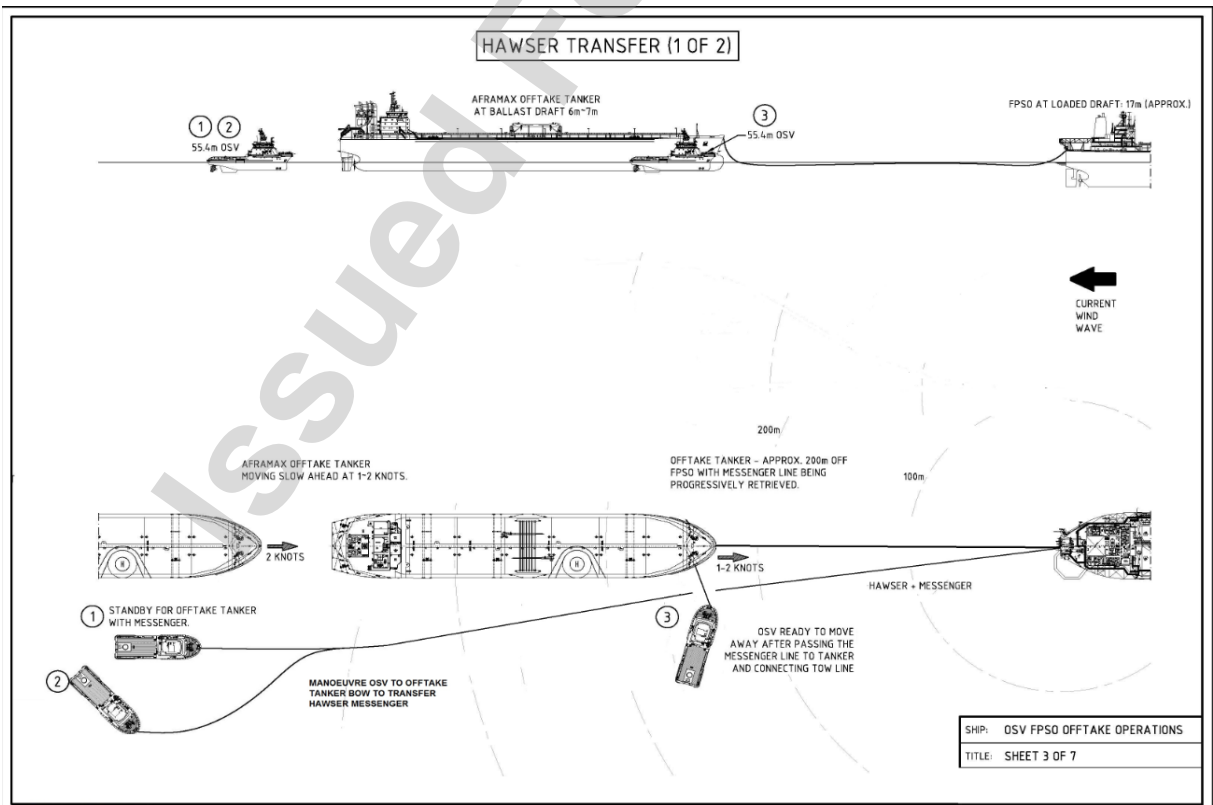
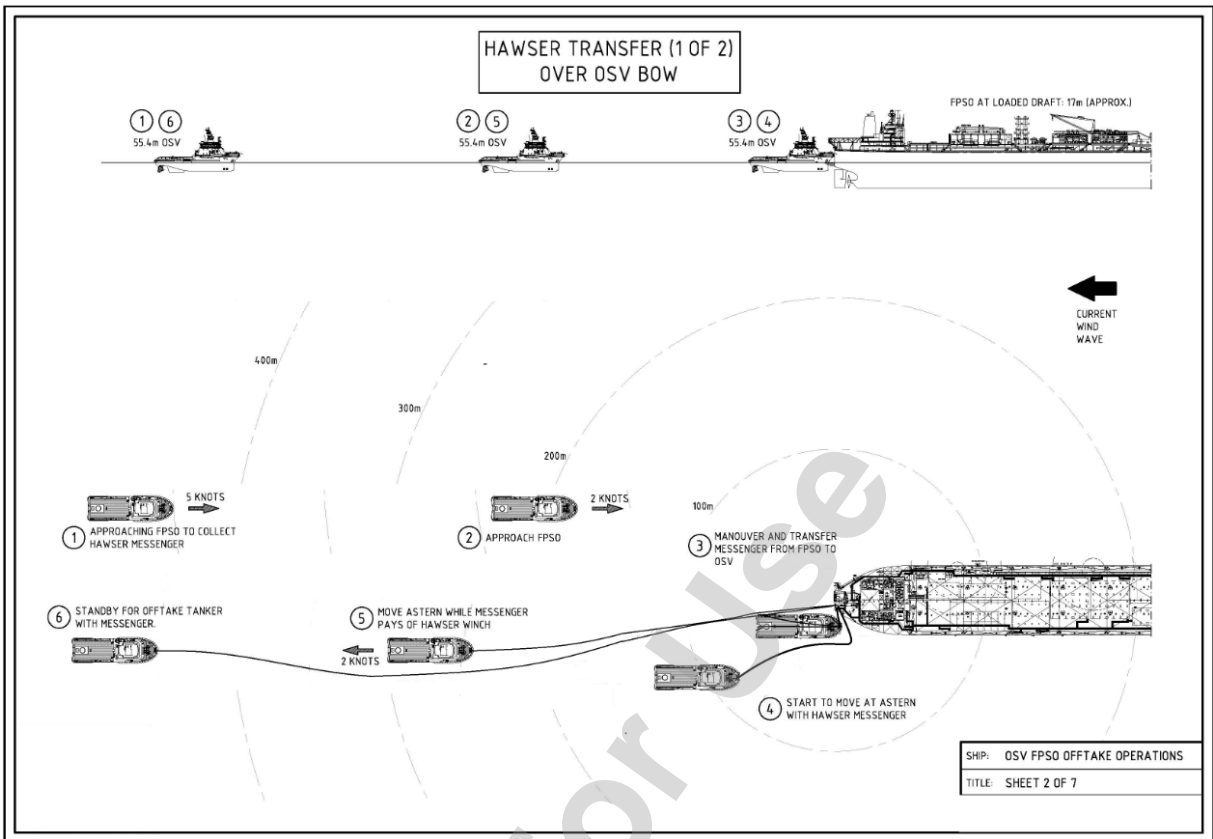

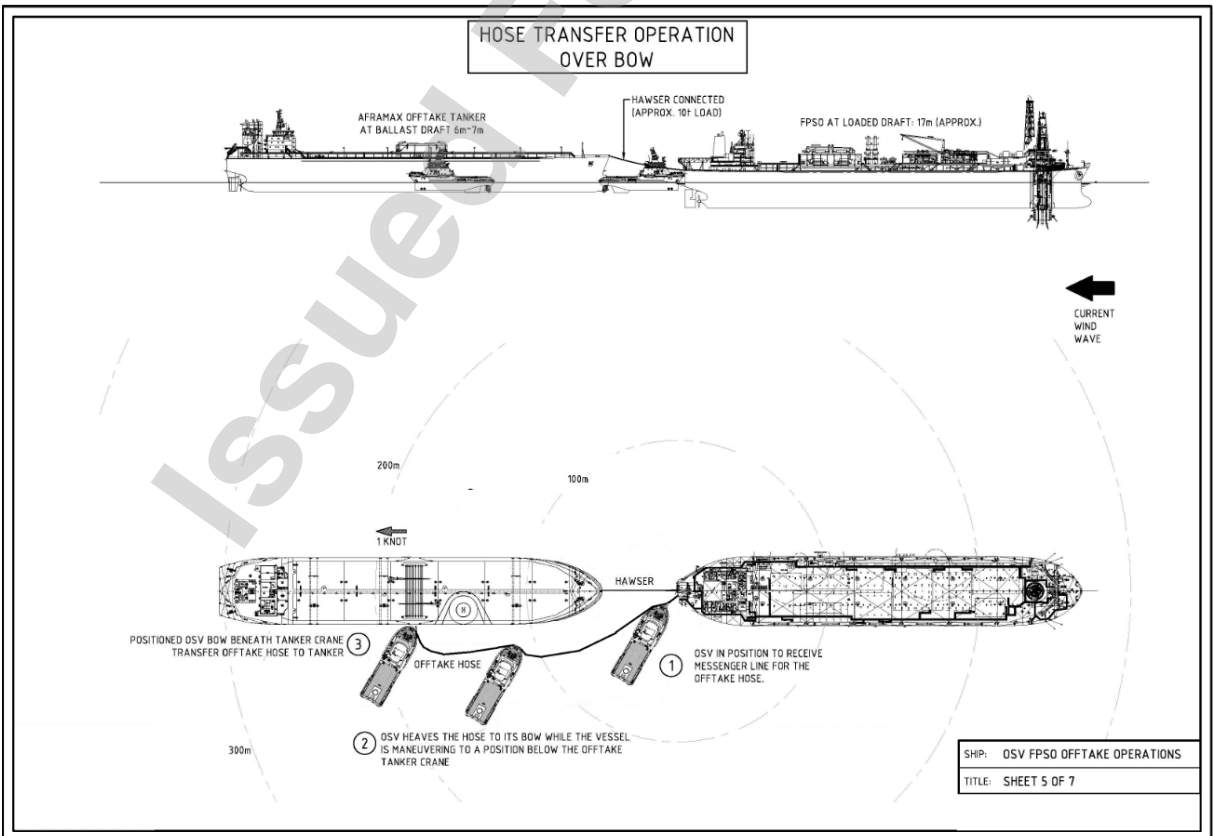
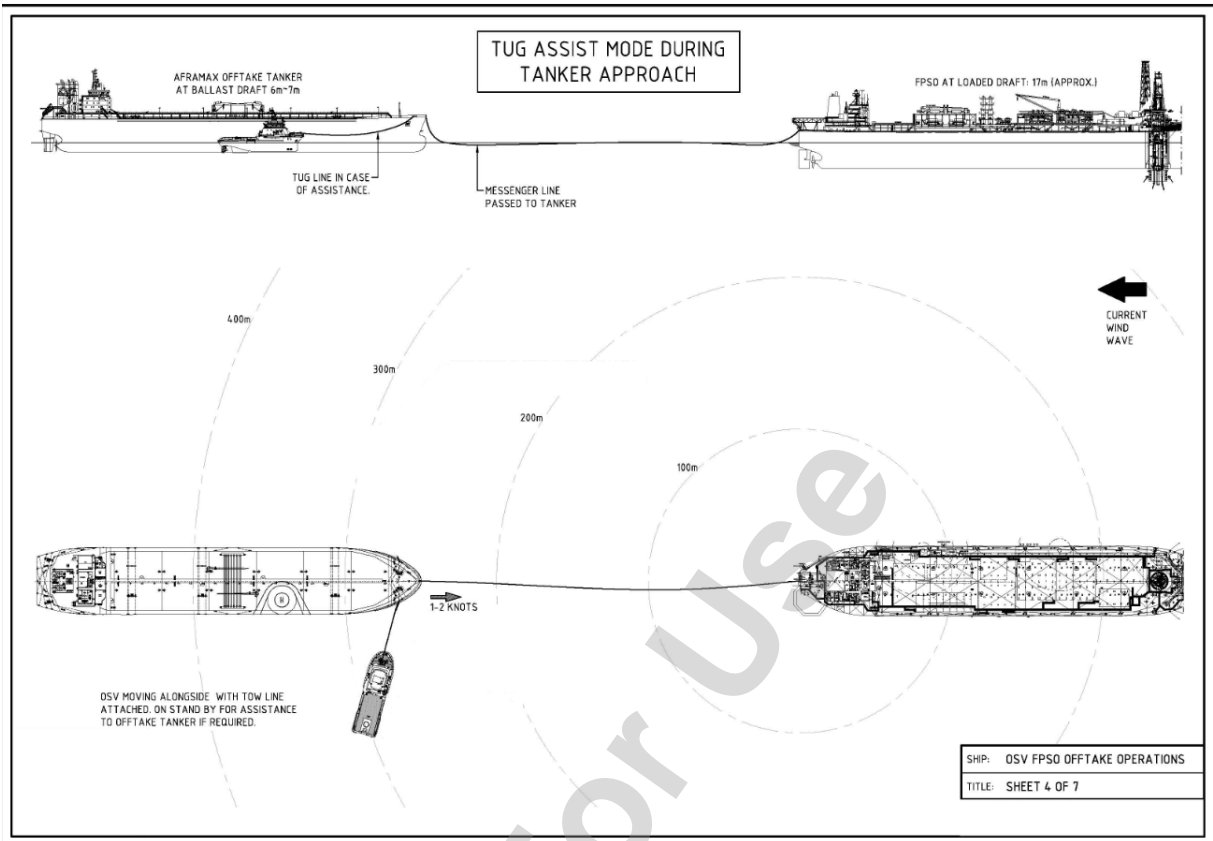

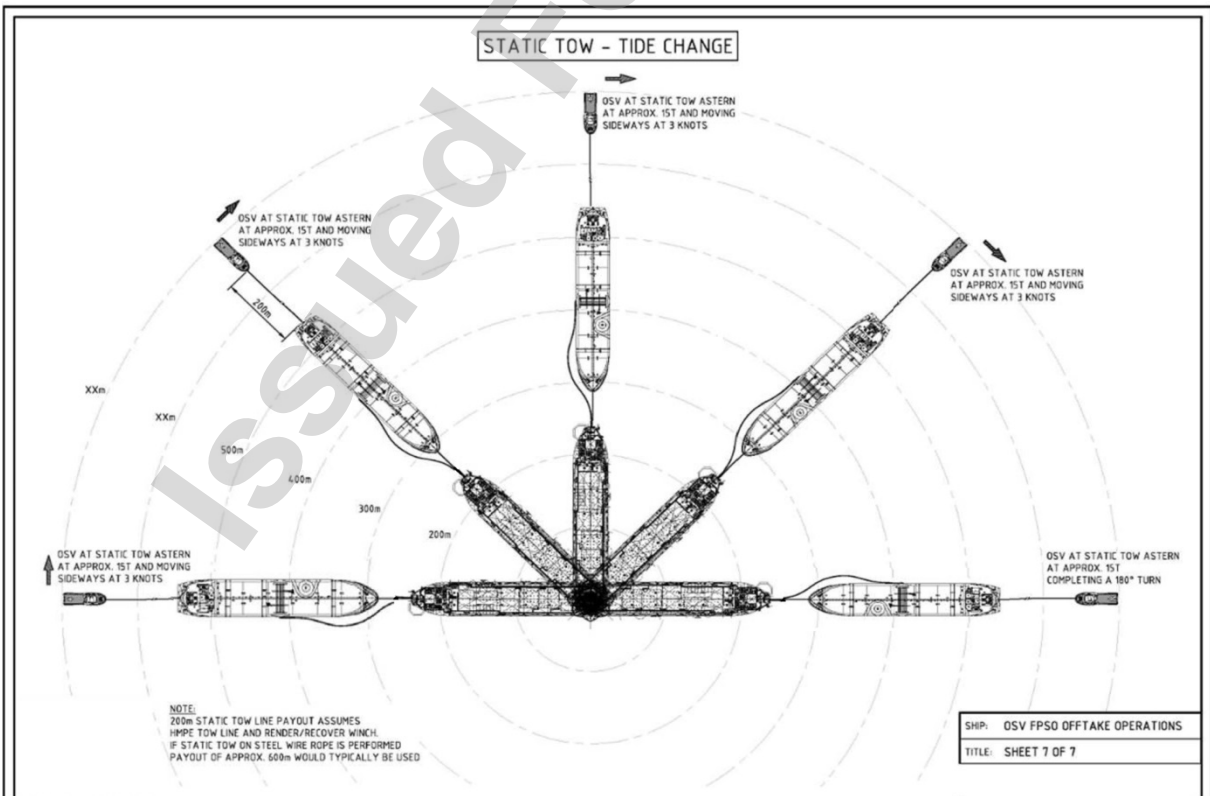
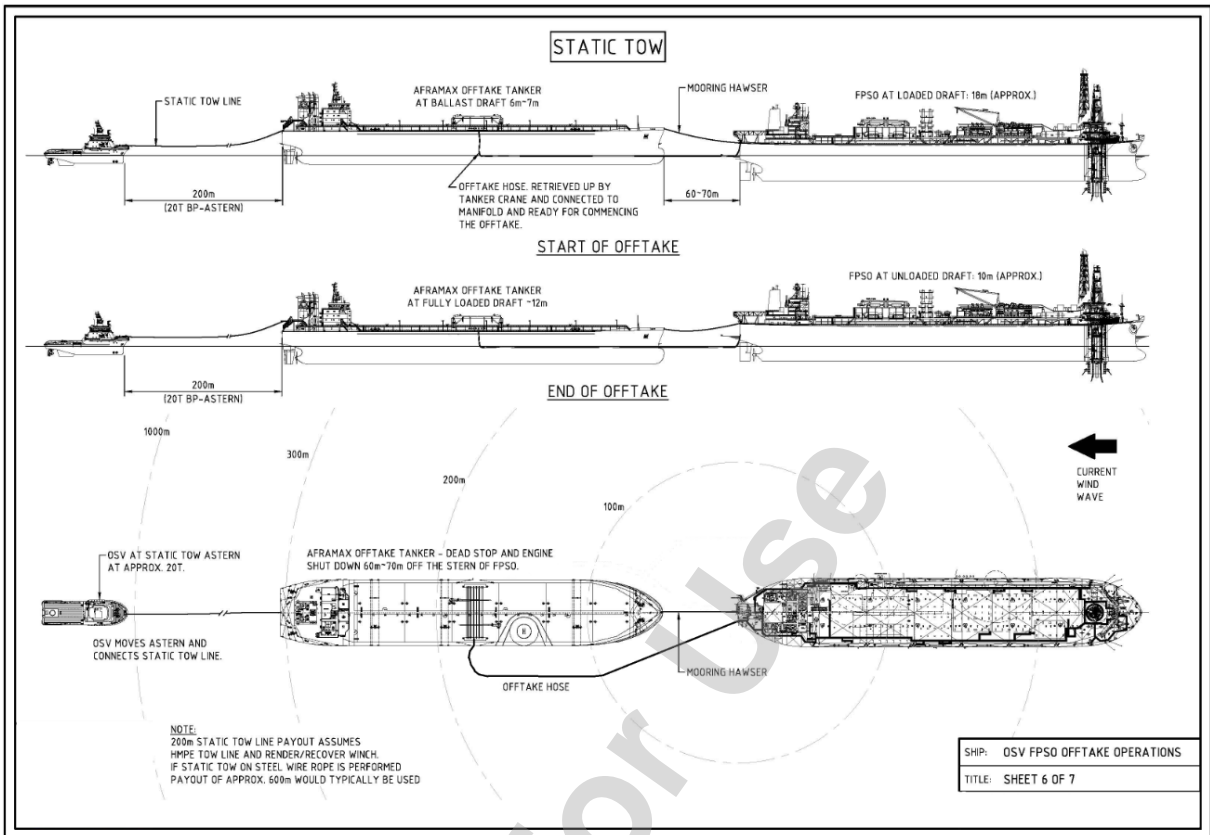

C.19 Special Instructions

Important: The FPSO Terminal ESD System will stop the loading pumps and close FPSO export valves. This process takes 16 seconds to complete. It is critical to the safety of the loading equipment that the Tanker hydraulic valves in the loading system do not close faster than the Terminal valves. To allow for this we ask that the Tanker confirm that the closing time for their loading system hydraulic valves is 'Greater Than 26 Seconds'.

The Offtake Tanker's manifold valve must only be opened and closed under the direction of both the Responsible Officer and the Terminal Representative.

The primary Terminal Representative will be in the Offtake Tanker's Cargo Control Room for the commencement and completion of cargo loading operations, and at all other times deemed necessary. The secondary Terminal Representative will monitor the commencement of cargo loading operations from the Offtake Tanker's manifold and remain at the Offtake Tanker's manifold until the agreed full loading rate is achieved and the manifold area integrity is confirmed.

The Offtake Tanker Responsible Officer must take any action required to ensure the safety of the Terminal, Offtake Tanker, personnel and environment as deemed necessary.

Any cargo system leaks must be reported to the Terminal Representative immediately.

The Offtake Tanker manifold must be attended by a member of the Offtake Tanker's crew at all times.

The Offtake Tanker's air conditioning system shall be set to maintain a positive pressure within the accommodation during cargo loading operations.

Offtake Tanker Stability

It is a Terminal requirement that all cargo and ballast operations are undertaken in accordance with the Offtake Tanker's Class / Administration approved loading manual and that a positive metacentric height of not less than zero decimal one five (0.15) metres (corrected for free surface) in the Seagoing Condition will be maintained throughout.

Ballast Operations

It is a Terminal requirement that ballast should be retained onboard the Offtake Tanker until sufficient bodily sinkage or trim reduction is achieved, in order to minimise excessive vessel motions whilst moored to the Terminal.

The Offtake Tanker de-ballasting rate is to be commensurate to the Terminal cargo loading rate.

APPENDIX D: GLOSSARY

Term	Definition
AIS	Automatic Identification System
AMSA	Australian Maritime Safety Authority
BDC	Brewster Drill Centre
CCR	Central Control Room
CPF	Central Processing Facility
DGPS	Differential Global Positioning System
EDP	Early Departure Procedure
ESD	Emergency Shut Down
ETA	Estimated Time of Arrival
FLA	Ichthys Field Condensate Lifting Agreement
FPSO	Floating Production Storage and Offloading
IAW	In Accordance With
ICSS	Integrated Control and Shutdown System
INPEX	INPEX Operators Australia Pty Ltd
IMO	International Maritime Organisation
IMPA	International Marine Pilot's Association
IMR	Inspection Maintenance and Repair
Inert gas	Gas such as nitrogen, or a mixture of non-flammable gasses

Term	Definition
	containing insufficient oxygen to support combustion
Intrinsically safe	Equipment or wiring incapable of causing ignition of a hazardous atmosphere
ISGOTT	International Safety Guidelines for Oil Tankers and Terminals 5th Ed 2006
ISM	International Safety Management
ISPS code	International Ship and Port Facility Security Code
ISSC	International Ship Security Certificate
Lifter	Lifter means a Party with a lifting entitlement under the Ichthys JOA, including a group of such Parties having elected to pool such entitlements under clause 8.2 of the FLA
LNG	Liquefied Natural Gas
LOA	Length Over All
LPG	Liquefied Petroleum Gas
MARSEC	Maritime Security Level
MSIC	Maritime Security Identification Card
MV	Motor Vessel
MTOFSA	Maritime Transport and Offshore Facilities Security Act
NoR	Notice of Readiness
OCIMF	Oil Companies International Marine Forum
OSZ	Offshore Security Zone
PFSO	Port Facility Security Officer

Term	Definition
PoB	Pilot on Board
PPE	Personal Protective Equipment
PSZ	Petroleum Safety Zone
SMPEP	Shipboard Marine Pollution Emergency Plan
SOPEP	Shipboard Oil Pollution Emergency Plan
SSZ	Ships Security Zone
SIRE	Ship Inspection Report
SPA	Sales and Purchase Agreement
SSP	Ship Security Plan
TORZ	Tanker Operations Restricted Zone
UHF	Ultra-High Frequency
VHF	Very-High Frequency
WLL	Working Load Limit (previously Safe Working Load)

Document Endorsement and Approvals

This page has been automatically generated and appended to this document by the INPEX Australia Document Management System (DMS). This page contains key events related to this document that are listed in the tables below and the information is unable to be manually edited.

Document Identification

Document Number	Revision	Security Classification	Date
X060-A1-MAN-60002	3	Public	14/02/2019

Document Revision History

Revision	Date and Time	Issue Reason
2A	05/02/2019 11:05	SQUAD Check
2B	06/02/2019 09:54	Approve with Endorsement

Delegation of Authority

From Name	To Name	Date and Time	Action
-----------	---------	---------------	--------

Name	Title
------	-------

Electronic Endorsement and Approval

Electronic approval of this document complies with the issued INPEX Electronic Approval Standard (0000-A9-STD-60011) and records evidence that the applicable person has either endorsed and/or approved the content contained within this document. The reviewers of this document are recorded in the DMS.

Name	Title	Date and Time	Action
Bruce Macgregor	Marine Manager	06/02/2019 10:21	Endorsed
Neville Carrington	General Manager Offshore Operations	14/02/2019 09:23	Approved